

**Electromagnetic compatibility
and Radio spectrum Matters (ERM);
Recommended approach, and possible limits for
measurement uncertainty for the measurement of
radiated electromagnetic fields above 1 GHz**



Reference

RTR/ERM-TG33-059-C1

Keywords

measurement uncertainty, mobile, radio, testing

ETSI

650 Route des Lucioles
F-06921 Sophia Antipolis Cedex - FRANCE

Tel.: +33 4 92 94 42 00 Fax: +33 4 93 65 47 16

Siret N° 348 623 562 00017 - NAF 742 C
Association à but non lucratif enregistrée à la
Sous-Préfecture de Grasse (06) N° 7803/88

Important notice

Individual copies of the present document can be downloaded from:

<http://www.etsi.org>

The present document may be made available in more than one electronic version or in print. In any case of existing or perceived difference in contents between such versions, the reference version is the Portable Document Format (PDF). In case of dispute, the reference shall be the printing on ETSI printers of the PDF version kept on a specific network drive within ETSI Secretariat.

Users of the present document should be aware that the document may be subject to revision or change of status.

Information on the current status of this and other ETSI documents is available at

<http://portal.etsi.org/tb/status/status.asp>

If you find errors in the present document, send your comment to:

editor@etsi.org

Copyright Notification

No part may be reproduced except as authorized by written permission.
The copyright and the foregoing restriction extend to reproduction in all media.

© European Telecommunications Standards Institute 2003.
All rights reserved.

DECTTM, **PLUGTESTS**TM and **UMTS**TM are Trade Marks of ETSI registered for the benefit of its Members.
TIPHONTM and the **TIPHON logo** are Trade Marks currently being registered by ETSI for the benefit of its Members.
3GPPTM is a Trade Mark of ETSI registered for the benefit of its Members and of the 3GPP Organizational Partners.

Contents

Intellectual Property Rights	6
Foreword.....	6
Introduction	6
1 Scope	7
2 References.....	8
3 Definitions, symbols and abbreviations	9
3.1 Definitions.....	9
3.2 Symbols	12
3.3 Abbreviations	12
4 Accuracy and measurement uncertainty	12
4.1 Introduction.....	12
4.2 Accuracy of measurement.....	12
4.3 Measurement uncertainty.....	13
5 Application of measurement uncertainty to specification limits	13
5.1 Introduction.....	13
5.2 Development of the "shared risk" concept.....	14
5.3 Shared risk, the new approach.....	14
5.3.1 Maximum acceptable measurement uncertainty.....	15
5.3.2 Guidance on compliance assessment when measurement uncertainty is equal to or less than maximum acceptable uncertainty.....	15
5.3.3 Guidance on compliance assessment when measurement uncertainty is greater than maximum acceptable uncertainty.....	15
5.4 Assessment for market surveillance and enforcement	16
5.4.1 Market surveillance.....	16
5.4.2 Enforcement	16
6 The role of standards (or specifications).....	16
6.1 Introduction.....	16
6.2 The players.....	16
6.3 The drafting of standards	17
6.4 The content of standards.....	17
6.5 Specification limits	17
7 The role of calibration in measurement uncertainty.....	17
7.1 Introduction to calibration.....	17
7.2 Test site calibration.....	18
7.2.1 Calibration of OATS.....	18
7.2.2 Calibration of semi-anechoic rooms	18
7.2.3 Calibration of fully lined anechoic rooms	19
7.3 Antenna calibration	19
7.4 Test equipment calibration.....	19
7.5 Automated test system calibration	19
8 Recommended maximum measurement uncertainties for RF electromagnetic field measurements.....	20
8.1 Introduction.....	20
8.2 Substitution measurement methods	20
8.2.1 Effective Isotropic Radiated Power (EIRP) (radio).....	20
8.2.2 Radiated spurious emissions (radio)	20
8.2.3 Receiver sensitivity (radio).....	20
8.3 Single measurement methods.....	20
8.3.1 Radiated emissions (EMC)	20
8.3.2 Radiated immunity (EMC)	21
8.3.3 Radiated receiver blocking (radio)	21

9	Controlling measurement uncertainty	21
9.1	Introduction.....	21
9.2	Test laboratory accreditation.....	21
9.3	Competence of the test laboratory	22
9.4	Skill level of test engineers and supervision of testing.....	22
9.5	Design and validation of appropriate test sites.....	22
9.6	Quality of test methods given in standards.....	23
9.7	Validation of test methods.....	23
9.8	Test instrumentation.....	23
9.9	Documentation	24
Annex A: History of the "shared risk" concept.....		25
A.1	Interpretation of the measurement results (ETS 300 086 Edition 1).....	25
A.2	Interpretation of the measurement results (EN 300 086-1 V1.2.1).....	25
A.3	Interpretation of the measurement results (EN 301 681 V1.3.2).....	26
Annex B: Examples of measurement uncertainty calculations		27
B.1	Effective Isotropic Radiated Power (EIRP) (radio)	27
B.2	Radiated spurious emissions (radio)	30
B.3	Receiver sensitivity (radio)	31
B.4	Radiated field strength (EMC)	32
B.5	Radiated immunity (EMC).....	33
B.6	Radiated receiver blocking (radio).....	34
Annex C: Example electronic files for calculation of measurement uncertainty.....		35
Annex D: Uncertainty contributions		36
D.1	Reflectivity	37
D.2	Mutual coupling	38
D.3	Range length.....	43
D.4	Corrections	44
D.5	Radio frequency cables.....	45
D.6	Phase centre positioning	46
D.7	Not used.....	48
D.8	Ambient signals	48
D.9	Mismatch	49
D.10	Signal generator.....	51
D.11	Insertion losses	51
D.12	Antennas	52
D.13	Receiving device.....	54
D.14	Equipment under test.....	55
D.15	Not used.....	57
D.16	Not used.....	57
D.17	Not used.....	57
D.18	Random uncertainty	57

D.19 Summary, tables and figures58
History.....62

Intellectual Property Rights

IPRs essential or potentially essential to the present document may have been declared to ETSI. The information pertaining to these essential IPRs, if any, is publicly available for **ETSI members and non-members**, and can be found in ETSI SR 000 314: "*Intellectual Property Rights (IPRs); Essential, or potentially Essential, IPRs notified to ETSI in respect of ETSI standards*", which is available from the ETSI Secretariat. Latest updates are available on the ETSI Web server (<http://webapp.etsi.org/IPR/home.asp>).

Pursuant to the ETSI IPR Policy, no investigation, including IPR searches, has been carried out by ETSI. No guarantee can be given as to the existence of other IPRs not referenced in ETSI SR 000 314 (or the updates on the ETSI Web server) which are, or may be, or may become, essential to the present document.

Foreword

This Technical Report (TR) has been produced by ETSI Technical Committee Electromagnetic compatibility and Radio spectrum Matters (ERM).

Introduction

The present document has been produced in response to the need for measurement uncertainty information above 1 GHz, and to determine practical maximum frequency of measurement which is also cost effective for manufacturers self declaration, and for test laboratories offering certification testing.

Considerable work on radio test methods and measurement uncertainty up to 1 GHz has previously been undertaken by ETSI to determine the contributions to the calculation of measurement uncertainty and these have been published in TR 100 028 [1] to [2] and TR 102 273 [3] to [10].

The changing role of regulation due to the implementation of the Radio and Telecommunications Terminal Equipment (R&TTE) Directive [11] within the European Union has meant that there is a need to review and if necessary revise the previously agreed method for the comparison of measurement values with limits to determine conformance with standards and specifications.

As a result of discussions with manufacturers, test laboratories, and regulators it is clear that some test methods need to be reviewed and more clearly defined as the frequency of measurement increases above 1 GHz. The re-defining of test methods is not within the scope of the present document, but may result in a more extensive evaluation of the test methods, bearing in mind the globalisation of radio products, and the implementation of Mutual Recognition Agreements (MRA) for this purpose.

From an international perspective, measurements for radio testing, both radio parameters and EMC, are already required above 1 GHz, notably in US FCC regulations (40 GHz), ITU-R spurious emissions (300 GHz), and CISPR EMC testing (under discussion to 6 GHz). These extensions to the measurement frequency range necessitate a review and some level of co-ordination to ensure that a common approach to test methods and the associated measurement uncertainty calculations are agreed.

The present document does not attempt to repeat the detailed statistical methods to calculate measurement uncertainty that has already been extensively prepared in other ETSI deliverables. However, to assist test engineers to calculate their own measurement uncertainties associated with their particular test equipment configurations, a series of spread sheets are attached to the present document (see annex C).

1 Scope

The present document presents an evaluation of maximum acceptable measurement uncertainty for Radio Frequency (RF) electromagnetic field (emf) measurements above the frequency one gigahertz (1 GHz) for inclusion within ETSI harmonized standards and radio product standards used for compliance testing.

The recommended maximum acceptable measurement uncertainty is given for the following measurement parameters:

radiated RF power;

radiated spurious emissions; and

EMC radiated emissions.

The maximum frequency recommendations are based upon current capabilities of measurement equipment *at May 2003* and the ability to calculate measurement uncertainty from traceable calibration certificates. Frequencies above the recommended maximum frequency for each method of measurement are for further study.

A recommendation is given on how to apply the laboratory calculated measurement uncertainty to a measured parameter and to assess the quality of the measurement against a defined limit given in a standard.

The present document contains the results of many discussions held with test equipment manufacturers, test laboratories, administrations, trade associations, societies, and members of the GRSC, all who have an interest in measurement uncertainty above 1 GHz.

In determining the maximum acceptable measurement uncertainty, particular account has been taken of current methods of measurement already identified in ETSI standards. However where there is an inconsistency, or uncertainties that have not previously been taken into account in the uncertainty budgets, these are clearly identified in the relevant clauses.

Whilst an analysis has been carried out on safety related measurements by ETSI, the responsibility for standards rests with CENELEC. The present document will include any recommendations from CENELEC TC 106X related to radiated measurements in a future edition.

Fixed link microwave methods of measurement do not use radiated measurements only conducted measurements (excepting EMC testing). Therefore they are considered outside the scope of the present document. However, as new technologies with integral antennas are being developed, this may be reviewed in a future edition.

Satellite equipment is outside the scope of the present document, however, this may be reviewed in a future edition.

The measurement uncertainty for conducted measurements is outside the scope of the present document.

The use of a test jig for radiated RF measurements of integral antenna radio equipment is outside the scope of the present document.

Annex A contains historical examples of the application of shared risk within ETSI standards.

Annex B contains examples of measurement uncertainty calculations, some of which are still under development.

Annex C is reserved for data files to be used in the calculation of radio parameter measurement uncertainties.

Annex D contains a list of all relevant contributions to radiated measurement uncertainty extracted from TR 102 273-1-2 [4].

2 References

For the purposes of this Technical Report (TR), the following references apply:

- [1] ETSI TR 100 028-1: "Electromagnetic compatibility and Radio spectrum Matters (ERM); Uncertainties in the measurement of mobile radio equipment characteristics; Part 1".
- [2] ETSI TR 100 028-2: "Electromagnetic compatibility and Radio spectrum Matters (ERM); Uncertainties in the measurement of mobile radio equipment characteristics; Part 2".
- [3] ETSI TR 102 273-1-1 (V1.2.1): "Electromagnetic compatibility and Radio spectrum Matters (ERM); Improvement on Radiated Methods of Measurement (using test site) and evaluation of the corresponding measurement uncertainties Part 1: Uncertainties in the measurement of mobile radio equipment characteristics; Sub-part 1: Introduction".
- [4] ETSI TR 102 273-1-2 (V1.2.1): "Electromagnetic compatibility and Radio spectrum Matters (ERM); Improvement on Radiated Methods of Measurement (using test site) and evaluation of the corresponding measurement uncertainties; Part 1: Uncertainties in the measurement of mobile radio equipment characteristics; Sub-part 2: Examples and annexes".
- [5] ETSI TR 102 273-2 (V1.2.1): "Electromagnetic compatibility and Radio spectrum Matters (ERM); Improvement on Radiated Methods of Measurement (using test site) and evaluation of the corresponding measurement uncertainties; Part 2: Anechoic chamber".
- [6] ETSI TR 102 273-3 (V1.2.1): "Electromagnetic compatibility and Radio spectrum Matters (ERM); Improvement on Radiated Methods of Measurement (using test site) and evaluation of the corresponding measurement uncertainties; Part 3: Anechoic chamber with a ground plane".
- [7] ETSI TR 102 273-4 (V1.2.1): "Electromagnetic compatibility and Radio spectrum Matters (ERM); Improvement on Radiated Methods of Measurement (using test site) and evaluation of the corresponding measurement uncertainties; Part 4: Open area test site".
- [8] ETSI TR 102 273-5 (V1.2.1): "Electromagnetic compatibility and Radio spectrum Matters (ERM); Improvement on Radiated Methods of Measurement (using test site) and evaluation of the corresponding measurement uncertainties; Part 5: Striplines".
- [9] ETSI TR 102 273-6 (V1.2.1): "Electromagnetic compatibility and Radio spectrum Matters (ERM); Improvement on Radiated Methods of Measurement (using test site) and evaluation of the corresponding measurement uncertainties; Part 6: Test fixtures".
- [10] ETSI TR 102 273-7 (V1.2.1): "Electromagnetic compatibility and Radio spectrum Matters (ERM); Improvement on Radiated Methods of Measurement (using test site) and evaluation of the corresponding measurement uncertainties; Part 7: Artificial human beings".
- [11] Directive 1999/5/EC of the European Parliament and of the Council of 9 March 1999 on radio equipment and telecommunications terminal equipment and the mutual recognition of their conformity.
- [12] LAB24: "Measurement Traceability and Calibration in the Mechanical Testing of Metallic Materials".
- [13] CISPR 16-4: "Specification for radio disturbance and immunity measuring apparatus and methods - Part 4: Uncertainty in EMC measurements".
- [14] Directive 98/34/EC of the European Parliament and of the Council of 22 June 1998 laying down a procedure for the provision of information in the field of technical standards and regulations/as amended.
- [15] CISPR 16-1: "Specification for radio disturbance and immunity measuring apparatus and methods - Part 1: Radio disturbance and immunity measuring apparatus".

- [16] ETSI ETS 300 086 (1991): "Radio Equipment and Systems (RES); Land mobile group; Technical characteristics and test conditions for radio equipment with an internal or external RF connector intended primarily for analogue speech".
- [17] ETSI EN 300 086-1 (V1.2.1): "ElectroMagnetic Compatibility and Radio Spectrum Matters (ERM); Land Mobile Service; Radio equipment with an internal or external RF connector intended primarily for analogue speech; Part 1: Technical characteristics and methods of measurement".
- [18] ETSI EN 301 681 (V1.3.2): "Satellite Earth Stations and Systems (SES); Harmonized EN for Mobile Earth Stations (MESs) of Geostationary mobile satellite systems, including handheld earth stations, for Satellite Personal Communications Networks (S-PCN) in the 1,5/1,6 GHz bands under the Mobile Satellite Service (MSS) covering essential requirements under article 3.2 of the R&TTE Directive".
- [19] ISO/IEC 17025(1999): "General requirements for the competence of testing and calibration laboratories".

3 Definitions, symbols and abbreviations

3.1 Definitions

For the purposes of the present document, the following terms and definitions apply:

accuracy: in relation to the measured value, in clause 4.2; it has also been used in the rest of the document in relation to test instrumentation

antenna: part of a transmitting or receiving system that is designed to radiate or to receive electromagnetic waves

antenna factor: quantity relating the strength of the field in which the antenna is immersed to the output voltage across the load connected to the antenna

NOTE: When properly applied to the meter reading of the measuring instrument, yields the electric field strength in V/m or the magnetic field strength in A/m.

antenna gain: ratio of the maximum radiation intensity from an (assumed lossless) antenna to the radiation intensity that would be obtained if the same power were radiated isotropically by a similarly lossless antenna

correction factor: numerical factor by which the uncorrected result of a measurement is multiplied to compensate for an assumed systematic error

confidence level: probability of the accumulated error of a measurement being within the stated range of uncertainty of measurement

directivity: ratio of the maximum radiation intensity in a given direction from the antenna to the radiation intensity averaged over all directions (i.e. directivity = antenna gain + losses)

error of measurement (absolute): result of a measurement minus the true value of the measurand (see clause 4.2).

error (relative): ratio of an error to the true value

estimated standard deviation: from a sample of n results of a measurement the estimated standard deviation is given by the formula:

$$s = \sqrt{\frac{\sum_{i=1}^n (x_i - \bar{x})^2}{n}}$$

x_i being the i^{th} result of measurement ($i = 1, 2, 3, \dots, n$) and \bar{x} the arithmetic mean of the n results considered.

A practical form of this formula is:

$$s = \sqrt{\frac{Y - \frac{X^2}{n}}{n}}$$

where X is the sum of the measured values and Y is the sum of the squares of the measured values.

NOTE: The term **standard deviation** has also been used in the present document to characterize a particular probability density. Under such conditions, the term **standard deviation** may relate to situations where there is only one result for a measurement.

expansion factor: multiplicative factor used to change the confidence level associated with a particular value of a measurement uncertainty

error (of a measuring instrument): indication of a measuring instrument minus the (conventional) true value (see clause 4.2)

free field: field (wave or potential) that has a constant ratio between the electric and magnetic field intensities

free space: region free of obstructions and characterized by the constitutive parameters of a vacuum

impedance: measure of the complex resistive and reactive attributes of a component in an alternating current circuit

impedance (wave): complex factor relating the transverse component of the electric field to the transverse component of the magnetic field at every point in any specified plane, for a given mode

influence quantity: quantity which is not the subject of the measurement but which influences the value of the quantity to be measured or the indications of the measuring instrument

isotropic radiator: hypothetical, lossless antenna having equal radiation intensity in all directions

measuring system: complete set of measuring instruments and other equipment assembled to carry out a specified measurement task

measurement repeatability: closeness of the agreement between the results of successive measurements of the same measurand carried out subject to all the following conditions:

- the same method of measurement;
- the same observer;
- the same measuring instrument;
- the same location;
- the same conditions of use;
- repetition over a short period of time.

measurement reproducibility: closeness of agreement between the results of measurements of the same measurand, where the individual measurements are carried out changing conditions such as:

- method of measurement;
- observer;
- measuring instrument;
- location;
- conditions of use;
- time.

measurand: quantity subjected to measurement

polarization: for an electromagnetic wave, this is the figure traced as a function of time by the extremity of the electric vector at a fixed point in space

quantity (measurable): attribute of a phenomenon or a body that may be distinguished qualitatively and determined quantitatively

quiet zone: a region within an anechoic chamber that complies with the Normalised Site Attenuation (NSA) requirements of being reflection free

NOTE: The term “quiet zone” does not imply that the physical dimensions of equipment under test can equal the same dimensions. The maximum size of the equipment is determined in accordance with TR 102 273-1-1, subclause 8.3.4. when related to range length and frequency of measurement.

shielded enclosure: structure that protects its interior from the effects of an exterior electric or magnetic field, or conversely, protects the surrounding environment from the effect of an interior electric or magnetic field

stochastic (random) variable: variable whose value is not exactly known, but is characterized by a distribution or probability function, or a mean value and a standard deviation (e.g. a measurand and the related measurement uncertainty)

uncertainty: parameter, associated with the result of a measurement, which characterizes the dispersion of the values that could reasonably be attributed to that measurement

uncertainty (random): component of the uncertainty of measurement, which, in the course of a number of measurements of the same measurand, varies in an unpredictable way (and has not being considered otherwise)

uncertainty (systematic): component of the uncertainty of measurement, which, in the course of a number of measurements of the same measurand remains constant or varies in a predictable way

uncertainty (type A): uncertainties evaluated using the statistical analysis of a series of observations

uncertainty (type B): uncertainties evaluated using other means than the statistical analysis of a series of observations

uncertainty (limits of uncertainty of a measuring instrument): extreme values of uncertainty permitted by specifications, regulations etc. for a given measuring instrument

NOTE: This term is also known as "tolerance".

uncertainty (standard): for each individual uncertainty component, an expression characterizing the uncertainty for that component

NOTE: It is the standard deviation of the corresponding distribution.

uncertainty (combined standard): uncertainty characterizing the complete measurement or part thereof

NOTE: It is calculated by combining appropriately the standard uncertainties for each of the individual contributions identified in the measurement considered or in the part of it that has been considered. In the case of additive components (linearly combined components where all the corresponding coefficients **are equal to one**) and when all these contributions are independent of each other (stochastic), this combination is calculated by using the Root of the Sum of the Squares (the RSS method). A more complete methodology for the calculation of the combined standard uncertainty is given in TR 100 028-2 [2], clause D.3.12.

uncertainty (expanded): expanded uncertainty is the uncertainty value corresponding to a specific confidence level different from that inherent to the calculations made in order to find the combined standard uncertainty

NOTE: The combined standard uncertainty is multiplied by a constant to obtain the expanded uncertainty limits (see TR 100 028-2 [2], clause D.5.6.2).

3.2 Symbols

For the purposes of the present document, the following symbols apply:

°C	degrees Centigrade
cms	centimetres
dB	deciBel
GHz	GigaHertz
MHz	MegaHertz
mV	milliVolt

3.3 Abbreviations

For the purposes of the present document, the following abbreviations apply:

EIRP	Effective Isotropic Radiated Power
EMC	ElectroMagnetic Compatibility
emf	electromagnetic fields
EUT	Equipment Under Test
FCC	Federal Communications Commission
NRA	National Regulatory Authority
OATS	Open Area Test Site
R&TTE	Radio and Telecommunications Terminal Equipment (Directive)
RF	Radio Frequency
SDO	Standard Development Organization
UKAS	United Kingdom Accreditation Service

4 Accuracy and measurement uncertainty

4.1 Introduction

The terms "accuracy" and "uncertainty" are frequently misused and interchanged when applied to measurement equipment and to a measured value (measurand). The following clauses define the meaning of each of the phrases and how they are used in measurement equipment literature. The difference in their meanings can be significant and in many measurement applications it is **vital** to understand the difference.

The use of the term "accuracy" plays a significant role in measurement equipment sales literature often to compete against similar equipment from other manufacturers and this should be regarded with caution. It has been known for competing manufacturers to quote performance values that exceed the finest metrology laboratory values for calibration and this of course is impossible. Realistic values are derived from traceable standards where the term "accuracy" is never used; only the term "uncertainty" is used. The true value of a measurand is never known, as it is impossible to define or make perfect measurements.

When a measurand with its measurement uncertainty bounds is compared with a specification (standard) limit interpretation of the result is not always clear. Clause 5 of the present document gives guidance on how to make this assessment, which is dependant upon the testing regime that is being followed.

4.2 Accuracy of measurement

The term "accuracy of measurement" is defined by international agreement as:

the closeness of the agreement between the result of a measurement and a true value of the measurand.

The full definition also states that accuracy is a qualitative concept and it can be attributed to be "high accuracy" or "low accuracy". In linguistic terms "accuracy" has a positive feeling and is easily accepted by engineers.

In practice, therefore, the definition is often redefined into a quantitative expression given as follows:

the difference between a measurand and the true value expressed as "accurate to $\pm X$ ".

This interpretation of the meaning immediately falls down for the reason given in clause 4.1, i.e. the true value is never known.

The use of the term "accurate to $\pm X$ " can also lead to confusion within the manufacturers organization, particularly in financial terms. Given that the reference standard states that the maximum acceptable measurement uncertainty is, let us say, ± 6 dB, and an investment request is made for a measurement receiver. Manufacturers specifications for differently priced measurement receivers states accuracy for three instruments as ± 2 dB, ± 3 dB and ± 4 dB at a price of 20 k Euros, 15 k Euros and 10 k Euros it is easy to see the equipment that the financial controller is prepared to pay for. However, the manufacturers specification only relates to the actual value measured at the cable entry point to his receiver and does not take into account all the other additional components which make up the total measurement uncertainty of the overall test set-up.

4.3 Measurement uncertainty

The term "measurement uncertainty" is defined by international agreement as:

a parameter, associated with the result of a measurement, that characterizes the dispersion of values that could reasonably be attributed to the measurand.

This definition makes no attempt to define the true value, nor does it rely upon it. It is a statistical approach and is used to give a level of confidence that the measured value lays between a range of values. In linguistic terms "uncertainty" has a negative feeling and is not easily accepted by engineers.

The calculation of uncertainty is, to say the least, complex, and the test engineer has to have extensive knowledge of the test system that is making the measurement, and, at the same time, have some reasonable knowledge of how the equipment under test should perform.

ETSI has produced substantial reports on the subject in TR 102 273 [3] to [10] and it is not intended to reproduce the information here.

The present document will use the previous work as reference to determine maximum acceptable measurement uncertainty to be used when measuring RF electromagnetic fields above 1 GHz.

Having surveyed a number of existing ETSI specifications where measurement uncertainty and accuracy are confused the following clauses attempt to clarify this situation.

5 Application of measurement uncertainty to specification limits

5.1 Introduction

ETSI developed an interpretation for the application of measurement uncertainty when assessing compliance to specification limits from the outset of producing standards for radio products in 1991 (see annex A). This interpretation only related to the measured value (the measurand). If the measurand was equal to or below the limit the equipment was deemed to meet the requirement of the relevant standard. However, the test laboratory did not make the decision. The testing was subject to third party mandatory testing (which still exists in many countries around the world) and the National Regulatory Authorities (NRA) made the decision as to compliance to the standard. The test laboratory was required to declare their measurement uncertainty as part of the Accreditation process to carry out the testing on behalf of the NRA.

This assessment was declared as "shared risk" between the manufacturer and the NRA. The manufacturer accepted the risk that the product may exceed the limit specified in the standard, and the NRA accepted the risk that the product equalled or was below the limit specified in the relevant conformance standard.

This situation was acceptable to all parties, particularly to the test laboratories who had to declare their measurement uncertainty but did not have to judge whether a product conformed to the limits set in the standard; the NRA carried out this function.

5.2 Development of the "shared risk" concept

As a consequence of deregulation under the Radio and Telecommunications Terminal Directive [11] mandatory type testing is no longer required. The method for compliance is normally by self-certification provided the standard used is a harmonized standard published under the requirements of the Directive. This implies that the manufacturer now declares his compliance to the harmonized standard, and not the NRA as before. Therefore the contract between external laboratories (when they are used) and manufacturers is now different. The manufacturer has to state with confidence that his product meets the specification, whilst the test laboratory only states his measurement with a measurement uncertainty in a report.

A number of expert bodies have therefore developed refinements on the original shared risk concept to assist manufacturers and test laboratories in reaching a compliance/non compliance assessment against limits given in product standards. The new "shared risk" concept has developed somewhat differently in differing organizations. In the UK the LAB34 [12] document from the United Kingdom Accreditation Service (UKAS), detailing "The Expression of Uncertainty in EMC Testing" provides a modified test approach when assessing against a specification limit. CISPR 16-4 [13] gives insight into what to do if the test laboratory measurement uncertainty exceeds the maximum acceptable uncertainty given in the relevant product standard.

ETSI, in the meantime, is reviewing the shared risk issues within the present document. To have shared risk implies that the risks are shared by a minimum of two parties. In the old regime of mandatory type testing the two parties were the NRAs and the manufacturer. Today there are no NRAs involved in the compliance assessment under the R&TTE Directive [11]. It is assumed that the manufacturers who self certify compliance would therefore wish to share the risk of compliance/non-compliance with the test laboratory when measurements are close to the limit and within the limits of measurement uncertainty declared by the test laboratory.

Where a manufacturer carries out testing for compliance within their own test facility there is no second party to share the risk of compliance/non-compliance with - they themselves have to share the risk between their own test facility and the quality organization making the declaration of compliance.

In the absence of harmonized standards, or the use of other means allowed under the R&TTE directive to prove compliance, there are now two parties involved, the manufacturer and a Notified Body. Under this regime the Notified Bodies decides if a product meets or does not meet the essential requirements of the Directive. It is therefore possible to use the shared risk approach in this assessment.

When a product has a complaint made against it that it is causing interference to radio services, the shared risk approach can still be used providing of course that the National Authorities accept the concept.

In those countries where third party testing is still the normal assessment of products then the old methods of "shared risk" are still valid.

5.3 Shared risk, the new approach

Taking all the current documentation on the issue into account, it is reasonable to redefine the shared risk approach to cover the new situations of deregulation as follows:

- 1) all standards where measurements are made for compliance testing should include maximum acceptable measurement uncertainty values for each test;
- 2) guidance should be given on assessing the measurements against defined limits in the standard when the measurand is close to the limit;
- 3) in the case where laboratory measurement uncertainty is greater than the maximum acceptable uncertainty stated in the standard, guidance should be given on assessing compliance to standard limits.

This approach combines the current documented solutions in CISPR, ETSI, and UKAS.

5.3.1 Maximum acceptable measurement uncertainty

In most ETSI radio equipment standards a table of maximum acceptable measurement uncertainty is included as a normative requirement. The table generally contains a list of the required measurement methods and their associated uncertainty.

The purpose of the table is to ensure that measurement uncertainty is controlled and that a wide variation of measured results between test laboratories is minimized. This approach also assists the process of laboratory accreditation for testing to the standard.

In discussion with test laboratories, they indicated that it would be extremely useful to associate directly the specification limit given in the standard with the required maximum allowable measurement uncertainty for the measured value.

As frequency ranges increase it may be difficult to conclude a maximum allowable value for the measurement uncertainty due to lack of knowledge of the new methods of test and determining the uncertainty components. Therefore some flexibility should be allowed to deviate from the initially determined maximum allowable values and this is dealt with in clause 5.3.3.

5.3.2 Guidance on compliance assessment when measurement uncertainty is equal to or less than maximum acceptable uncertainty

The interpretation of the results when comparing measurement values with specification limits should be as follows:

- a) when the measured value does not exceed the limit value the equipment under test meets the requirements of the standard;
- b) when the measured value exceeds the limit value the equipment under test does not meet the requirements of the standard;
- c) the measurement uncertainty calculated by the test technician carrying out the measurement should be recorded in the test report;
- d) the measurement uncertainty calculated by the test technician may be a maximum value for a range of values of measurement, or may be the measurement uncertainty for the specific measurement undertaken. The method used should be recorded in the test report.

5.3.3 Guidance on compliance assessment when measurement uncertainty is greater than maximum acceptable uncertainty

The interpretation of the results when comparing measurement values with specification limits should be as follows:

- a) when the measured value plus the difference between the maximum allowable measurement uncertainty and the measurement uncertainty calculated by the test technician does not exceed the limit value the equipment under test meets the requirements of the standard;
- b) when the measured value plus the difference between the maximum allowable measurement uncertainty and the measurement uncertainty calculated by the test technician exceeds the limit value the equipment under test does not meet the requirements of the standard;
- c) the measurement uncertainty calculated by the test technician carrying out the measurement should be recorded in the test report;
- d) the measurement uncertainty calculated by the test technician may be a maximum value for a range of values of measurement, or may be the measurement uncertainty for the specific measurement undertaken. The method used should be recorded in the test report.

5.4 Assessment for market surveillance and enforcement

5.4.1 Market surveillance

For the purposes of market surveillance the interpretation of results should follow that given in subclauses 5.3.2 and 5.3.3 using the test methods given in the relevant standard. The testing laboratory should be competent in accordance with ISO/IEC 17025 [19] and be formally accredited to carry out the relevant tests given in the appropriate standard.

5.4.2 Enforcement

Enforcement of the limits given in the relevant standard, when market surveillance indicates that a product exceeds the relevant limit, is the responsibility of the individual National Regulatory Authority as provided for in EU Directives.

6 The role of standards (or specifications)

6.1 Introduction

Continuing confusion exists due to the fact that the term "standard" has been misused within the telecommunications industry for many years by referring to such documents as "de facto" or "proprietary" standards, whilst the more formal definitions have been avoided. This clause outlines the principal definitions required to identify what is a "standard", and gives the priority by which standards are applied:

technical specification: A specification contained in a document which lays down the characteristics required of a product such as levels of quality, performance, safety or dimensions, including requirements applicable to the product as regards terminology, symbols, testing and test methods, packaging, marking or labelling.

standard: A technical specification approved by a recognized standardizing body (*e.g. European Telecommunications Standards Institute (ETSI)*) for repeated or continuous application, with which compliance is not compulsory.

European standards: A standard that has been approved pursuant to the statutes of the standards bodies with which the Community has concluded agreements.

technical regulation: Technical specifications, including the relevant administrative provisions, the observance of which is compulsory, *de jure* or *de facto*, in the case of marking or use in Member States or a major part thereof, except those laid down by local authorities.

harmonized standard: Technical specifications (ENs or HDs) adopted by CEN/CENELEC or ETSI on a basis of a remit from the Commission in accordance with the provisions of Council Directives and in accordance with the General Guidelines.

The above definitions have been extracted from a number of European Directives related to the application of standards within the Community.

6.2 The players

In the field of telecommunications in Europe, and in a wider worldwide area, a number of players have an interest.

On an International scale the interests rest with ITU-T for general telecoms, and ITU-R for radio issues. ISO/IEC also have an interest in some areas.

Within Europe the interests rests with CEN/CENELEC and ETSI, being recognized as being competent to prepare European Standards. This recognition in the European Union is provided by the application of European Commission Directive 94/34/EC [14].

For regulatory issues within the European Union a number of Directives are used, specifically related to telecommunications terminals. For the whole of Europe radio equipment interests are further represented by CEPT/ERC who have the responsibility for efficient use of the frequency spectrum and the allocation of specific frequency bands to be used for specific services and in some cases for specific equipment.

6.3 The drafting of standards

For any new radio technology, the drafting of standards for the EU is a joint effort between the Standard Development Organization (SDO) and the relevant CEPT Committee. The CEPT organization is responsible for the spectrum allocation, the controlled parameters, and efficient use of the frequency spectrum, whereas the SDO is responsible for the application of the CEPT recommendations within a standard. Outside the EU the relevant European National Administration works with CEPT and a National standards body or an SDO.

Compliance to the overall requirements given in a standard is demonstrated in a number of ways as defined in Community Directives for radio terminals, marine equipment, aeronautical equipment and automobile equipment.

Standards developed in the SDO committees are approved by consensus within the relevant Member States or directly by the SDO membership.

Outside the EU the National administration may chose to use a "Type Approval" regimen or adopt the EU compliance criteria.

6.4 The content of standards

For compliance testing the standards contain specification limits, test methods, and compliance interpretation for the parameters considered to be required to manufacture a radio product and place it on the market. Recent changes to compliance testing requirements have already been alluded to, and as a consequence the content of a standard has to be clear and precise. Lack of precision in test methods can have serious consequences, leading to confusion within testing organizations and the inability to define associated measurement uncertainty of measurements made by the test laboratory.

Clause 9 of the present document further elaborates on the needs of test methods when related to measurement uncertainty.

6.5 Specification limits

The specification limits provided within standards are used to determine compliance with the requirements within the standard. These limits are derived in a number of ways; they are the result of spectrum studies undertaken by CEPT, recommendations from ITU-R that have been implemented by CEPT, decisions made in international standards produced by CISPR to name a few.

The limits derived for radio equipment parameters are different to those derived for EMC due to the different application of the measurement test methods. Radio parameters are defined as a radiated power value directly at the source and this is used to assess the protection to and from other radio services. EMC parameters are defined as a radiated field strength value at a distance from the source normally at three metres or ten metres.

The derivation of the specification limit has a direct impact on the measurement method; radio parameters are normally measured using substitution techniques whereas EMC test methods use a single measurement technique. The consequence is that measurement uncertainty calculations contain different uncertainty contributions. This is reflected in the typical measurement uncertainty calculations given in annex B for what appears at first sight as the same measurement.

7 The role of calibration in measurement uncertainty

7.1 Introduction to calibration

To determine the "quality" of any part of a test system it is necessary to place a tolerance on the extreme measurement uncertainty applicable to the test equipment measurement capability. This is achieved via traceable reference standards that are of a higher quality than that of the test equipment being examined.

Traceability is achieved by using primary reference standards held by National Metrology Laboratories to calibrate secondary reference standards that are then used to calibrate general-purpose test equipment. Primary reference standards are manufactured to the highest quality, are never used to make measurements, and comparisons are made on a regular basis between the metrology laboratories to further refine the measurement uncertainty when comparing secondary standards to the primary reference standards.

Test equipment used for EMC and radio testing is considered as general-purpose test equipment that has been calibrated to secondary reference standards. From this calibration, systematic errors can be determined (providing correction factors to be applied to a measurand) and the contribution to overall measurement uncertainty (from the measurement uncertainty declarations made by the calibration laboratory).

The following clauses address the calibration requirements for the various components of the overall test systems used to measure radiated RF fields.

Calibration of test equipment is normally carried out at a specific temperature e.g. 20°C, and therefore care should be taken to maintain the actual temperature when used to make formal measurements. Equipment used for calibration purposes is normally maintained in a controlled environment.

7.2 Test site calibration

RF field strength measurements both for EMC and radio parameters are normally performed on an Open Area Test Site (OATS) that have a clear and level terrain. Such sites are clear of buildings, electric cables, fences, trees and underground pipes and are only supplied with the necessary cabling to support the operation of the equipment under test, and the connections for making the necessary measurements. Specific instructions for the construction of an OATS can be found in CISPR 16-1 [15] for sites operating over the frequency range 30 MHz to 1 GHz. It should be noted that for both EMC and radio parameter testing a ground plane is required.

For testing above 1 GHz the OATS can be used subject to suitable calibration performance, and alternative test sites may be used. Current documentation only provides information to 18 GHz and does not cover the necessary performance of such a site above 1 GHz.

Research by a number of alternative site manufacturers has shown that testing can be carried out to 40 GHz with improved performance over the OATS. These alternative sites rely on semi-anechoic rooms, i.e. shielded rooms that have anechoic materials on the walls and ceiling whilst maintaining the ground plane.

The basis for the ± 4 dB acceptance criteria for site attenuation is given in CISPR 16-1 [15], annex L.

7.2.1 Calibration of OATS

The calibration of an OATS is given in CISPR 16-1 [15], clause 5.6.6 as well as annex G. These procedures and acceptance criteria are currently only valid up to 1 GHz, but have been shown to also work up to 18 GHz with suitable modifications. For the purposes of the ETSI requirements it is recommended to use the same test site validation procedures with the same ± 4 dB acceptance criteria until such time as an enhanced formal procedure is available from CISPR.

7.2.2 Calibration of semi-anechoic rooms

The calibration of semi-anechoic rooms (an alternative test site) is given in CISPR 16-1 [15], clause 5.6.7 up to 1 GHz. This method has been used by the room manufacturers up to 40 GHz and the results have shown that above 3 GHz to 18 GHz the deviation of the site attenuation against the calculated theoretical value is less than ± 2 dB.

The method given in the reference above determines a volume of measurement area and the research shows that a quiet zone of 2,5 metres can be determined within the site attenuation limit of ± 4 dB.

Actual calibrations of semi-anechoic rooms show that the deviation from calculated theoretical values of site attenuation from 20 GHz to 40 GHz is $\pm 2,5$ dB.

7.2.3 Calibration of fully lined anechoic rooms

The calibration of fully lined anechoic rooms has not been formally defined in standards. It is well known that there is a difference of a few dBs when comparing this form of test site with test sites having a ground plane. The difference varies between 3 dB and 6 dB. In the absence of formal measurement methods for the calibration of fully lined anechoic rooms, this has been left for further investigation and determination in a future version of the present document.

NOTE: A draft ETSI Technical Specification is under development to provide the methods for validating an anechoic chamber up to 40 GHz to support the needs of radio testing.

7.3 Antenna calibration

Antenna calibration is used to determine the antenna factors applied as correction factors to measurements. A calibration test site can be constructed similar to the OATS. A procedure for the calibration of antennas is given in CISPR 16-1 [15], clause 5.13.

For antennae used above 1 GHz it is usual to have these calibrated by an independent calibration laboratory. Traceable calibration of antenna factors or antenna gain is available up to 40 GHz, for horizontal and vertical polarization, and at various measurement heights.

For antennae that have been calibrated for positive gain, i.e. directional antennae, it is important to also have the 3 dB beamwidth information to ensure that the antennae are correctly boresight aligned when making measurements.

7.4 Test equipment calibration

In the introduction given in clause 7.1 the traceability route for calibration purposes is described. Calibration laboratories follow very strict rules for each measurement parameter they declare in their published capability documents. This allows clients seeking calibration services to evaluate the laboratories' capability and select the level of measurement uncertainty that they may require which is fit for the purpose of the test equipment calibration. *Smaller* measurement uncertainty value given by the calibration laboratory generally implies greater cost.

The calibration laboratory selected will provide a calibration certificate which gives the measurand of the parameter tested with a statement of measurement uncertainty. From this certificate it is possible to determine any systematic errors to be used as a correction factor for measurand made with the test instrument. The declared measurement uncertainty on the certificate can be used as a contribution to the overall measurement uncertainty calculations declared by the test engineer in his test report.

Calibration of this nature is normally carried out at regular intervals e.g. yearly, six monthly, quarterly.

Some test equipment also has inbuilt calibration procedures defined by the manufacturer. These are normally carried out at power on and thereafter on a daily basis and this internal calibration is used to maintain the short-term quality of the calibration carried out by calibration laboratories.

In the same way as test laboratories have to maintain and declare their measurement uncertainties so calibration laboratories are required to do the same.

In researching the capabilities of independent calibration laboratories, providing calibration to industry, the upper limit of frequency capability is currently set at 40 GHz. Above this frequency calibration may be provided by test equipment manufacturers.

For the purposes of the present document the upper limit of frequency has been set at 40 GHz.

7.5 Automated test system calibration

Automated test systems, inclusive of computer controllers, can be very complex particularly when used to carry out protocol testing that relies on the use of a radio channel via integral antennae. The providers of such test systems have the responsibility to define the necessary calibration requirements. The present document does not evaluate such systems for calibration nor for their measurement uncertainty contributions. This subject area is for further study.

8 Recommended maximum measurement uncertainties for RF electromagnetic field measurements

8.1 Introduction

The following radio radiated measurement methods have been evaluated and the following clauses indicate the recommended values of maximum frequency and maximum allowable measurement uncertainty.

8.2 Substitution measurement methods

8.2.1 Effective Isotropic Radiated Power (EIRP) (radio)

Maximum frequency = 40 GHz

Maximum uncertainty = ± 6 dB

For the calculation of this value see annex B.

This value is dependent upon the maximum dimensions of the antenna of the equipment under test and is also dependent upon gain specifications of antennae.

8.2.2 Radiated spurious emissions (radio)

Maximum frequency = 40 GHz

Maximum uncertainty = ± 6 dB

For the calculation of this value see annex B.

This value is dependent upon the maximum dimension of the equipment under test upon the test site.

8.2.3 Receiver sensitivity (radio)

Maximum frequency = 40 GHz

Maximum uncertainty = ± 6 dB

For the calculation of this value see annex B.

8.3 Single measurement methods

8.3.1 Radiated emissions (EMC)

Maximum frequency 6 GHz

Maximum uncertainty = ± 6 dB

For the calculation of this value see annex B.

The measurement distance is defined within the test method. However, the current methods are limited to 1 GHz and therefore when new methods of measurement are defined by CISPR the measurement uncertainty should reflect that method of test. CISPR standards are under development above 1 GHz and therefore the present document may be amended to reflect the new test methods.

8.3.2 Radiated immunity (EMC)

Maximum frequency 18 GHz

Maximum uncertainty = ± 6 dB

For the calculation of this value see annex B.

The measurement distance is defined for a given radiated immunity field strength. As frequency increases different antennae may be used but should be in the far field region. CISPR standards are under development above 1 GHz and therefore the present document may be amended to reflect the new test methods.

8.3.3 Radiated receiver blocking (radio)

Maximum frequency 40 GHz

Maximum uncertainty = ± 6 dB

For the calculation of this value see annex B.

Receiver blocking test methods above 1 GHz are under review and may have an influence on the measurement uncertainty calculations. However the maximum uncertainty given here is considered as being correct. The physical size of antennae may have a significant impact on measurement uncertainty but this subject is for further development.

9 Controlling measurement uncertainty

9.1 Introduction

This clause presents the recommended processes and procedures to minimise measurement uncertainty. The following subjects are covered:

Test Laboratory Accreditation.

Competence of the Test Laboratory;

Skill level of test engineers and supervision of testing;

Design and validation of appropriate test sites;

Quality of test methods given in standards;

Validation of test methods;

Test instrumentation; and

Documentation.

The information provided in the following subclauses is applicable to formal third party independent test laboratories and also to any other laboratory (e.g manufacturers test laboratory) that is carrying out formal tests to prove compliance with a defined testing standard.

9.2 Test laboratory accreditation

A test laboratory has two main criteria to meet if it is to provide confidence to a client that a product is fit to be placed upon the market in accordance with current legislation. The test laboratory should declare which standards it is accredited to test against and provide evidence of competence to carry out the tests within a standard. Accreditation authorities ensure that test laboratories of type first party, second party, and third party can provide testing to an acceptable quality using ISO/IEC 17025 [19] as a reference.

NOTE: ISO/IEC 17025 [19] includes the requirements of ISO 9000 series quality standards.

9.3 Competence of the test laboratory

The competence of a test laboratory is judged directly in accordance with ISO 17025 [19]. As stated above the standard includes ISO 9000 series requirements but goes further in that it is not just a quality system. Each laboratory is judged on its technical capability to carry out testing and its quality procedures to ensure the validity of the results declared by the test laboratory to its clients.

The following subclauses discuss the additional requirements demanded by ISO/IEC 17025 [19] to ensure the technical and quality competence of a testing laboratory.

The descriptions below are not specific to radio and EMC test laboratories but to any test laboratory (including calibration laboratories). Any specific requirements for radio and EMC laboratories should be declared by the laboratory seeking accreditation, or should be declared in the requirements of any applicable standard.

9.4 Skill level of test engineers and supervision of testing

The management of an accredited test facility have the responsibility to ensure that the personnel are competent to operate test equipment, carry out testing, evaluate results and sign test reports. This implies that sufficient supervision is to be provided for engineers under training, and that test engineers have the necessary education, training and experience in the appropriate measurements being undertaken defined in standards used by the test laboratory.

The major source of confusion when assessing results obtained from different test laboratories is that considerable variation of measurement results on the same test sample can be easily identified. The causes for this anomaly can normally be traced to either insufficiently defined test methods that have then been interpreted by the test engineer or complacency by the test engineer due to the long period of testing.

Experiments have been carried out using a travelling test sample and then tested in two ways. The first is the circulation of the test sample to a number of test laboratories for testing to a defined test method and the second is the use of specific test equipment, test engineers who travel with the test sample and who carry out the testing on each test site.

Results of such experiments have been extensively analysed and show that in the first experiment considerable differences in measurement values can be seen, in a range of up to 15 dB. In the second experiment the measurement values are very close to each other, in a range of up to 1 dB. Considerable confusion exists in industry over these anomalies. Many believe the cause is measurement uncertainty, but in fact the anomalies are due to errors and interpretations made by the test engineer.

9.5 Design and validation of appropriate test sites

The current ETSI radio testing standards usually define an Open Area Test Site (OATS) as being the accepted test facility and this type of site is also defined for EMC measurements. The ETSI radio standards generally provide the option of using alternative test sites including semi and fully anechoic chambers.

EMC testing standards are generally limited to a maximum test frequency of between 1 and 3 GHz at defined test distances (3 or 10 metres). An OATS is perfectly acceptable to meet EMC objectives and thus ensuring interference capability when co-located with any other equipment in the same environment.

However the same cannot be said when considering the testing of radiated radio RF parameters. These parameters are tested to restrict the interference capability to other radio services. It has become common practice in recent years to specify the use of fully lined anechoic chambers within ETSI radio standards when test measurements are required above 1 GHz, thus providing a quiet RF environment for the testing.

When reviewing the ETSI test methods, and relating them to the appropriate regulatory requirements, radiated RF parameters are required to be made in the farfield of the frequency under investigation. However the definition of "farfield" is dependent upon the size of the equipment, the size of the receiving antenna and the frequency of the RF emission.

It is therefore recommended that standards should clearly state the type of test facilities that is to be used in relation to the frequency of measurement and the type of equipment under test. This also implies that the capability of test equipment to measure microwave frequencies in the farfield has to be clearly understood by the standards developers.

Having clearly identified the type of test site within the appropriate standards the validation of the site is important to ensure that the measurement uncertainty of any measurements that are made on the site are under control (see clause 7).

9.6 Quality of test methods given in standards

The quality of test methods given in standards is important to ensure the control of the tests to be carried out and ultimately will determine the measurement uncertainty of a measured result. Test laboratories are required to declare their testing capability and are accredited on their ability to fulfil the requirements stated in standards. The test laboratory is required to use test methods published in international, regional or national standards.

However where the methods are unclear in these reference standards internal test procedures are required to ensure consistency in the test methods used by the test engineers. In this case it is possible that each test laboratory may develop internal procedures that follow the spirit of the standards, but may interpret them in a slightly different way. This can lead then to anomalies in results between laboratories and lack of confidence by the client in the capability of the test methods in use.

It is important that test methods are validated and this is discussed in the next subclause.

9.7 Validation of test methods

It is the responsibility of the test laboratory to validate all test methods used within the test facility, and hence determines the measurement uncertainties associated with the test methods. This validation is normally carried out using a number of different approaches:

- 1) comparison of repeated results;
- 2) comparison of results carried out using different test methods;
- 3) inter-comparisons with other test laboratories using standard test samples;
- 4) assessment of factors that can influence the result of the measurement; and
- 5) the assessment of the measurement uncertainty of the results using a scientific understanding of the test method and practical experience.

Item 1) above is generally referred to as “measurement repeatability” and is used to judge the stability of a test set-up.

Item 2) above is generally referred to as “measurement reproducibility” and is used to assess the quality of test methods by changing the method of measurement, the test engineer, the measurement equipment, test site, and time separation between tests.

Item 3) above has been used successfully in the EMC environment but has been rarely used, if ever, within the radio parameter testing environment.

Items 4) and 5) above are normal activities in determining the measurement uncertainty of a measurement, or series of measurements, as part of the general accreditation procedures of the test laboratory.

9.8 Test instrumentation

As the frequency range of radio testing develops into the higher microwave regions test methods become more complex and test equipment considerably more expensive to purchase as the number of equipment manufacturers are reduced. Test equipment capability can also exceed the ability to have traceability of calibration techniques. At the same time novel technologies are under development for which at the time of preparing standards test equipment is not yet available on the open market.

Standards makers should take great care that in specifying test methods for specific parameters that they do not define specific manufacturers’ test equipment within the standards under their control. Advancing technologies often leaves the problem of testing to the test laboratories to solve and does nothing to assist the manufacturers responsibility to regulators of the market. As a consequence, standards makers often stay with test methods they already know of from previous technologies and these test methods are often not applicable to the new technologies.

Test instrumentation in radio testing has been clearly defined by agreement between the manufacturers, the testing organisations, and the accreditation authorities by common practice. This arrangement has been suitable for test methods up to about 18 GHz, but as specific requirements advances towards 300 GHz this situation changes dramatically.

The stability of test instrumentation has largely been driven by the development of test cables and connectors that provides the flexibility in carrying out the specific test procedures. In the 1980s this imposed a limitation of flexible testing to a frequency of 18 GHz above which it was necessary to change to waveguide techniques. Today cables and connectors are available to approximately 50 GHz, but traceable calibration at such frequencies is still limited to 40 GHz.

9.9 Documentation

Test laboratories are required to maintain a considerable amount of documentation not limited to just the required test procedures.

To minimise measurement uncertainty historical and current calibration data for all test equipment used for making the measurements is required to be maintained.

The control of technical reports and approval certificates is required to assist in any future evaluation that may be required by regulatory authorities. As deregulation has developed from a strict regulatory regime some demanded records are no longer being maintained due to the distinct lack of guidance on such issues within regulatory standards.

Testing standards are required to be maintained from a historical point of view and the latest edition of the testing standards have be easily available to all test personnel. This task is particularly onerous on the test laboratory as they are not always aware of new editions reaching the market from the standards organisations particularly when open public standards approval procedures are not used.

Annex A: History of the "shared risk" concept

The following clauses have been extracted from a sample of ETSI standards to show the current statements on interpretation of results. It can be seen that these statements vary between the documents and therefore should be aligned to avoid any confusion in their application.

A.1 Interpretation of the measurement results (ETS 300 086 Edition 1)

The interpretation of the results recorded in a report for the measurements described in this standard shall be as follows.

The measured value related to the corresponding limit will be used to decide whether equipment meets the requirements of the standard.

The measurement uncertainty value for the measurement of each parameter shall be included in the report.

The recorded value of the measurement uncertainty shall be, for each measurement, equal to or lower than the figures in clause 10 (table of measurement uncertainty).

NOTE: This procedure for using Maximum Acceptable Uncertainty values is valid until superseded by other appropriate publications of ETSI covering this subject.

The use of the measured value has been chosen because there is no other ETSI standard covering the subject at the time of publication of this standard. Therefore the measurement uncertainty shall be used as a quality of the actual measurement. Accreditation Authorities can also use the Measurement Uncertainty values during their accreditation procedures to ensure compliance/conformity with the requirements of type testing to ETSI Standards.

A.2 Interpretation of the measurement results (EN 300 086-1 V1.2.1)

The following text is the interpretation given in EN 300 086-1 [17], clause 4.3.

The interpretation of the results (e.g. results recorded in a report) for the measurements described in the present document shall be as follows:

- a) the measured value related to the corresponding limit shall be used to decide whether equipment meets the requirements for that parameter of the present document;
- b1) the values of the actual measurement uncertainty shall be, for each measurement, equal to or lower than the figures given in clause 11 (maximum acceptable values of the measurement uncertainties);
- b2) the actual measurement uncertainty of the laboratory carrying out the measurements, for each particular measurement, shall be included in the corresponding report (if any).

For the methods of measurement, according to the present document, the measurement uncertainty figures shall be calculated in accordance with TR 100 028 [1] to [2] and shall correspond to an expansion factor (coverage factor) $k = 1,96$ or $k = 2$ (which provide confidence levels of respectively 95 % and 95,45 % in the case where the distributions characterizing the actual measurement uncertainties are normal (Gaussian)).

The particular expansion factor used for the evaluation of the measurement uncertainty shall be stated.

A.3 Interpretation of the measurement results (EN 301 681 V1.3.2)

The following text is the interpretation given in EN 301 681 [18], clause 5.2.1.4.7.

The interpretation of the results for the measurements described in the present document shall be as follows:

- a) the measured value related to the corresponding limit shall be used to decide whether equipment meets the minimum requirements of the standard;
- b) the actual measurement uncertainty of the test laboratory carrying out the measurement, for each particular measurement, shall be included in the report;
- c) the values of the actual measurement uncertainty shall be, for each measurement, equal to or lower than the figures in clause 5.2.1.4.3.

Annex B: Examples of measurement uncertainty calculations

The examples in this annex reflect uncertainties gathered from test laboratory input, calibration uncertainties, examination of manufacturers specifications and the fixed values given in TR 102 273-1-2 [4].

The full calculation method is not shown in the following tables for simplicity. However, see annex C for the full calculation method.

The values given for overall measurement uncertainty are calculated for a confidence level of 95 % in each example unless otherwise stated.

Random uncertainty due to EUT performance has been excluded from the calculations on the basis that normally only one measurement is made. However, for measurements made close to the limit that invokes the need for a decision on compliance/non-compliance of the measured result, the random uncertainty should be included with a minimum of 10 measurements of the parameter. These results should be then used to calculate the new overall measurement uncertainty.

Not all the tables are yet complete, as the measurement methods are not yet stable. The next edition of the present document will address these issues.

B.1 Effective Isotropic Radiated Power (EIRP) (radio)

Table B.1: Typical EIRP measurement uncertainty calculation

Source of uncertainty	Value	Standard uncertainty	Comments
Stage 1: EUT Measurement			
Influence of setting power supply	±100 mV	0,03	
Influence of the ambient temperature	±1 °C	0,20	
Mutual coupling to the power leads	0,00	0,00	Above 1 GHz no influence.
Position of the phase centre within the EUT volume	±5 %	0,25	For EUT dimensions < 30 cms.
Positioning of the phase centre within the EUT over the axis of rotation of the turntable	±3 cms	0,05	
Range length	±3 cms	0,05	
Curvature of the phase front EUT to test antenna		0,30	
Site Factors			
Ambient effect	0,10 dB		With EUT off, the noise receiver floor > 10 dB below the measured value.
Mutual coupling: amplitude effect of the test antenna on the EUT	0,00	0,00	Range length $\geq 2(d_1+d_2)^2/\lambda$.
Mutual coupling: EUT to its images in the absorbing material		0,50	
Mutual coupling: EUT to its images in the ground plane		0,15	This value is zero when a fully anechoic room is used.
Reflectivity of absorbing material: EUT to the test antenna	0,00	0,00	Substitution method.
Mutual coupling: Test antenna to its images in the absorbing material	0,00	0,00	Substitution method.
Mutual coupling: Test antenna to its images in the ground plane	0,00	0,00	Substitution method.

Source of uncertainty	Value	Standard uncertainty	Comments
Test antenna			
Correction: measurement distance	0,00	0,00	Substitution method.
Correction: of boresight angle in elevation plane	0,00	0,00	Substitution method.
Antenna: gain of the test antenna	0,00	0,00	Substitution method.
Antenna: tuning of the test antenna	0,00	0,00	Fixed broadband ridged guide antenna. Substitution method.
Position of the phase centre: test antenna	0,00	0,00	Substitution method.
Insertion loss: test antenna attenuator	0,00	0,00	Substitution method.
Insertion loss: test antenna cable	0,00	0,00	Substitution method.
Cable factor: test antenna cable	0,00	0,00	Substitution method.
Receiving device			
Receiving device: absolute level	0,00	0,00	Substitution method.
Receiving device: linearity	0,00	0,00	Substitution method.
Random uncertainty	0,00	0,00	This uncertainty is derived from repeated measurements of the equipment under test, and is only important when the measured value is close to the specification limit.
Combined measurement uncertainty - Stage 1	$(0,47)^{0,5}$	0,69	
Stage two: Substitution measurement			
Mismatch uncertainty: transmitting parts and receiving parts		0,80	Signal generator to cable to antenna.
Signal generator: absolute output level		0,52	This value should be calculated dependant upon the measurement equipment used.
Signal generator: output level stability	0,00	0,00	Assumed to be included in the absolute out level uncertainty.
Insertion loss: substitution antenna cable	0,3	0,17	
Cable factor: substitution antenna cable		0,50	
Insertion loss: substitution antenna attenuator		0,17	
Antenna: gain of the substitution antenna		0,80	
Antenna: tuning of the substitution antenna		0,00	Fixed broadband ridged guide antenna.
Position of the substitution antenna: Phase centre		0,02	
Site Factors			
Ambient effect		0,00	Assumes the use of anechoic room.
Mutual coupling: Substitution antenna to its images in the absorbing material		0,50	
Mutual coupling: substitution antenna to the test antenna		0,00	
Range length		0,00	
Reflectivity of absorbing material: substitution antenna to the test antenna		0,50	Little is known of the performance of anechoic materials up to 40 GHz, therefore the nominal value has been used.
Mutual coupling: test antenna to its images in the absorbing material		0,50	Little is known of the performance of anechoic materials up to 40 GHz, therefore the nominal value has been used.
Mutual coupling: test antenna to its image in the ground plane	0,00	0,00	Assumes a fully lined anechoic room.
Correction measurement		0,10	

Source of uncertainty	Value	Standard uncertainty	Comments
distance			
Correction off boresight angle in elevation plane		0,10	
Antenna: gain of the test antenna	0,00	0,00	Substitution method.
Antenna: tuning of the test antenna	0,00	0,00	Fixed broadband ridged guide antenna. Substitution method.
Position of the phase centre: test antenna	0,00	0,00	Substitution method.
Insertion loss: test antenna attenuator	0,00	0,00	Substitution method.
Insertion loss: test antenna cable	0,00	0,00	Substitution method.
Cable factor: test antenna cable	0,00	0,00	Substitution method.
Receiving device: absolute level	0,00	0,00	Substitution method.
Receiving device: linearity	0,00	0,00	Substitution method.
Random uncertainty	0,00	0,00	This uncertainty is derived from repeated measurements of the equipment under test, and is only important when the measured value is close to the specification limit.
Stage 1 combined contribution to uncertainty		0,69	
Stage 2 combined contribution to uncertainty		1,62	
Combined contribution to uncertainty Stage 1 and Stage 2		1,76	
Expanded uncertainty (k = 2, 95 % confidence)		3,52	

It can be shown that the major influences on the overall measurement uncertainty are:

- 9 Stage 1: signal to noise at low levels of signal;
- 10 Stage 1: random uncertainty of the EUT;
- 11 Stage 2: Mismatch uncertainty;
- 12 Stage 2: Signal generator absolute power level; and
- 13 Stage 2: Random uncertainty of the measurement system.

B.4 Radiated field strength (EMC)

Table B.4: Typical radiated field strength measurement uncertainty calculation (at 3 m)

Source of uncertainty	Value	Standard uncertainty	Comments
Receiver Indication	0,05	0,03	This uncertainty is a function of the least significant digit of the receiver display readout, or the meter indication, or the marker function on an analyser.
Receiver sine wave	1,00	0,50	Receiver error due to sine wave voltage.
Receiver pulse amplitude	1,50	0,87	Receiver error due to pulse amplitude response.
Receiver pulse repetition	1,50	0,87	Receiver error due to pulse repetition response.
Noise floor proximity	0,50	0,25	Error only applicable when measuring within 10 dBs of the noise floor of the receiver.
Antenna factor calibration	1,00	0,50	The uncertainty of antenna factor is obtained from the calibration certificate.
Cable loss	0,50	0,25	The uncertainty of cable loss is obtained from the calibration certificate.
Antenna Directivity	3,00	1,73	This uncertainty varies with antenna type and measurement distance.
Antenna factor - height dependence	0,50	0,29	This uncertainty is based on experience of antenna calibration. The value given is typical for vertical polarization. With horizontal polarization can be as much as 2 dB. Above 1 GHz the uncertainty is much reduced when using horn type antennas .
Antenna phase centre variation	1,00	0,58	This uncertainty is based on experience of antenna calibration. Above 1 GHz the uncertainty is much reduced when using horn antennas.
Antenna factor frequency interpolation	0,25	0,14	This uncertainty depends on the frequency interval of calibration points and the rate of change of the antenna factor with frequency
Site imperfections	4,00	1,63	This uncertainty can be assessed from the site normalized site attenuation.
Measurement distance variation	0,60	0,35	This is an estimate of the uncertainty of received signal strength when related to the uncertainty of the measurement distance.
Antenna balance	0,00	0,00	Above 1 GHz this uncertainty is assumed to be zero.
Cross polarization	0,90	0,52	This uncertainty is dependant on the type of antenna used to make the measurement. Can be considered as zero when using horn antennas.
Frequency step error	0,00	0,00	This uncertainty is assumed to be zero. However can be significant if the frequency step size is not set correctly in relation to the receiver bandwidth. Recommended step size is half the receiver bandwidth for minimum uncertainty.
Mismatch receiver and cables	-0,54	0,38	This uncertainty is derived from the combination of the reflection coefficient magnitudes of the antenna/cable/receiver combination. Additional uncertainty can be introduced when using cable connector adaptors
Measurement system repeatability	0,50	0,50	This uncertainty is derived from a number of repeated measurements using a stable equipment under test (e.g. a reference noise source).
Repeatability of the EUT	0,00	0,00	This uncertainty is derived from repeated measurements of the equipment under test, and is only important when the measured

Annex C: Example electronic files for calculation of measurement uncertainty

Electronic files are under preparation to assist the test engineer to calculate the measurement uncertainties of the different measurement methods indicated in the present document. These files will be attached to the present document in electronic format in the next edition as part of support from a developed Measurement Uncertainty calculator available for distribution as “freeware” that has been developed to comply with current international opinion on the subject.

For those who wish to review the software it is currently available from the following website:

<http://metrologyforum.tm.agilent.com/download3.shtml>

This software has been evaluated for a number of test methods that have been previously defined in ETSI standards. Whilst the results of the evaluation indicate similar results for EMC tests, evaluation to cover the requirements of RF substitution methods has not yet been carried out. ETSI does not endorse the software but provides this information for those who wish to assess whether it is suitable for their own needs.

Annex D: Uncertainty contributions

This annex contains a list of the uncertainties identified as being involved in radiated tests and gives details on how their magnitudes should be derived. Numerical and alphabetical lists of the uncertainties are given in tables D.21 and D.22.

A radiated test, whether a verification procedure or the measurement of a particular parameter, consists of two stages. For verification procedure the first stage is to set a reference level followed by the second stage that involves a measurement of the path loss between two antennas. For EUT testing, the first stage is to measure the EUT followed by the second stage that involves comparing the result to a known standard or reference. As a result of this methodology there are measurement uncertainty contributions that are common to both stages of any test, some of which cancel themselves out, others are included once whilst yet others have to be included twice.

NOTE: For the measurement of some EUT receiver parameters the stages are reversed.

Converting data: In the evaluation of any particular contribution it may be necessary to convert given data (e.g. from a manufacturer's information) into standard uncertainty. The following will aid any conversions that may be necessary.

Mismatch uncertainties have 'U' shaped distributions. If the limits are $\pm a$ the standard uncertainty is: $a/\sqrt{2}$.

Systematic uncertainties e.g. the uncertainty associated with cable loss are, unless the actual distribution is known, assumed to have rectangular distributions. If the limits are $\pm a$ the standard uncertainty is: $a/\sqrt{3}$.

The rectangular distribution is a reasonable default model to choose in the absence of any other information.

For conversion of % to dB, table D1 should be used (for more information on the derivation of the table see TR 102 273-1-2 [4], annex C).

Table D.1: Standard uncertainty conversion factors

Converting from standard uncertainties in ...:	Conversion factor multiply by:	To standard uncertainties in ...:
DB	11,5	voltage %
DB	23,0	power %
power %	0,043 5	dB
power %	0,5	voltage %
voltage %	2,0	power %
voltage %	0,086 9	dB

Terminology: In this annex the following phases should be interpreted as follows:

- "Free field test sites": are Anechoic Chambers, Anechoic Chambers with Ground Planes and Open Area Test Sites.
- "Verification": refers to the measurement in which the test site is compared to its theoretical model.
- "Test methods": refers to all radiated tests apart from the verification procedure.
- "Transmitting" and "receiving" antennas: are used in the verification procedure only; all other references to antennas (i.e. substitution, measuring and test) are for test methods.

D.1 Reflectivity

Background: The absorber panels in Anechoic Chambers (both with and without ground planes) reflect signal levels that can interfere with the required field distribution.

U_{j01} Reflectivity of absorbing material: EUT to the test antenna

This uncertainty only contributes to test methods on free field test sites that incorporate anechoic materials. It is the estimated uncertainty due to reflections from the absorbing material.

How to evaluate for free field test sites

Verification: Not applicable.

Test methods: If the test is part of a substitution measurement the standard uncertainty is 0,00 dB, otherwise the value from table D.2 should be used.

Table D.2: Uncertainty contribution: reflectivity of absorbing material: EUT to the test antenna

Reflectivity of the absorbing material	Standard uncertainty of the contribution
reflectivity <10 dB	4,76 dB
10 dB ≤ reflectivity < 15 dB	3,92 dB
15 dB ≤ reflectivity < 20 dB	2,56 dB
20 dB ≤ reflectivity < 30 dB	1,24 dB
reflectivity ≥ 30 dB	0,74 dB

U_{j02} Reflectivity of absorbing material: substitution or measuring antenna to the test antenna

This uncertainty only contributes to test methods on free field test sites that incorporate anechoic materials. It is the estimated uncertainty due to reflections from the absorbing material.

How to evaluate for free field test sites

Verification: Not applicable.

Test methods: In a substitution type measurement the reflectivity of the absorber material tends to be nullified by the substitution methodology. However, there will always be some differences in the radiation patterns of the EUT and the substitution or measuring antenna and hence the standard uncertainty to allow for this should be taken as 0,5 dB.

U_{j03} Reflectivity of absorbing material: transmitting antenna to the receiving antenna

This uncertainty only contributes to the verification procedures on free field test sites that incorporate anechoic materials. It is the estimated uncertainty due to reflections from the absorbing material.

How to evaluate for free field test sites

Verification: The relevant value for this contribution should be taken from table D.3.

Table D.3: Uncertainty contribution: reflectivity of absorbing material: transmitting antenna to the receiving antenna

Reflectivity of the absorbing material	Standard uncertainty of the contribution
reflectivity <10 dB	4,76 dB
10 dB ≤ reflectivity < 15 dB	3,92 dB
15 dB ≤ reflectivity < 20 dB	2,56 dB
20 dB ≤ reflectivity < 30 dB	1,24 dB
reflectivity ≥ 30 dB	0,74 dB

Test methods: Not applicable.

D.2 Mutual coupling

Background: Mutual coupling is the mechanism which produces changes in the electrical behaviour of an EUT or antenna when placed close to a conducting surface, another antenna, etc. These mechanisms are illustrated in figure D.1. The effects can include de-tuning, gain variations, changes to the radiation pattern and input impedance, etc.

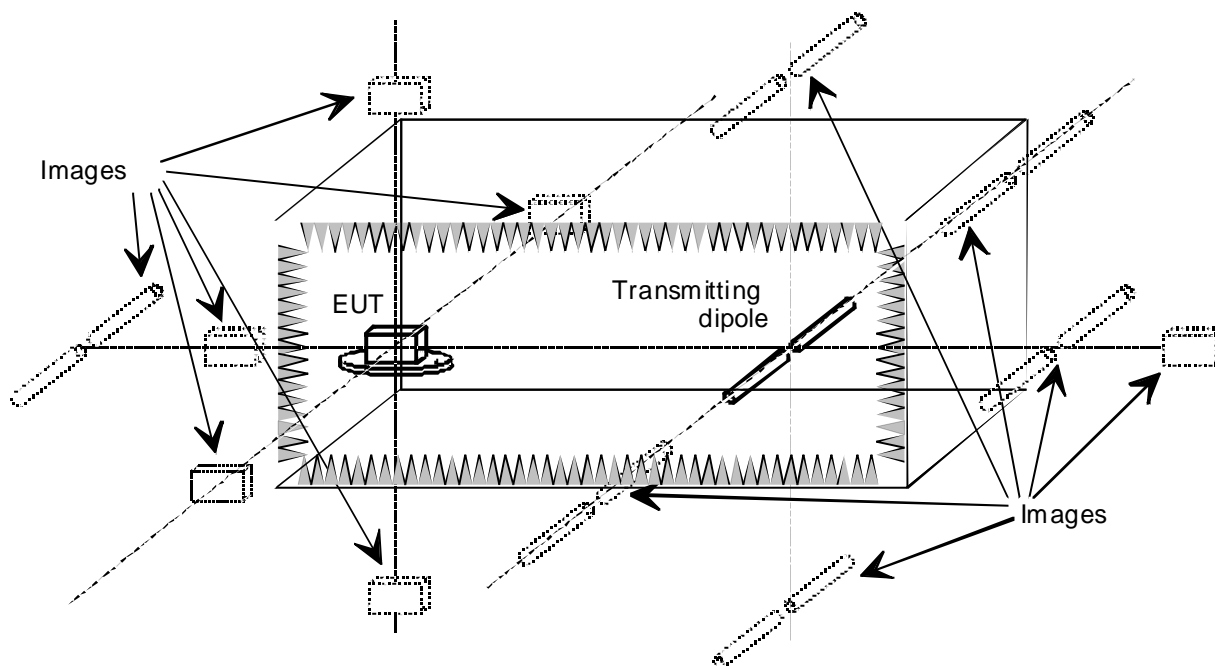

Figure D.1: Mutual coupling (Anechoic Chamber illustrated)

U_{j04} Mutual coupling: EUT to its images in the absorbing material

This uncertainty contributes to test methods and verification procedures on free field test sites that incorporate anechoic material. It is the uncertainty that results from the degree of imaging in the absorber/shield of the chamber and the resulting effect on the input impedance and/or gain of the integral antenna.

How to evaluate for free field test sites

Verification: Not applicable.

Test methods: The standard uncertainty is 0,50 dB.

U_{j05} Mutual coupling: de-tuning effect of the absorbing material on the EUT

This uncertainty only contributes to the test methods on free field test sites that incorporate anechoic materials. It is the uncertainty of any de-tuning effect due to the return loss of the absorbers.

How to evaluate for free field test sites

Verification: Not applicable.

Test methods: This value will be 0,00 Hz provided the absorbing panels are more than 1 m away from the EUT and the return loss of the panels is above 6 dB (testing should not take place for spacing of less than 1 m). For return losses below 6 dB, the value should be taken as 5 Hz standard uncertainty.

U_{j06} Mutual coupling: substitution, measuring or test antenna to its images in the absorbing material

This uncertainty only contributes to test methods on free field test sites that incorporate anechoic material. It is the uncertainty that results from the degree of imaging in the absorber/shield of the chamber and the resulting effect on the antenna's input impedance and/or gain.

How to evaluate for free field test sites

Verification: Not applicable.

Test methods:

- for the test antenna only, if it is at the same height for both stages one and two of the test method, then for any absorber depth the uncertainty is 0,00 dB, otherwise the standard uncertainty is 0,50 dB;
- for substitution or measuring antennas the standard uncertainty is 0,50 dB.

U_{j07} Mutual coupling: transmitting or receiving antenna to its images in the absorbing material

This uncertainty only contributes to verification procedures on free field test sites that incorporate anechoic material. It is the uncertainty that results from the degree of imaging in the absorber/shield of the chamber and the resulting effect on the antenna's input impedance and/or gain.

How to evaluate for free field test sites**Verification:**

- for the transmitting antenna the standard uncertainty is 0,50 dB;
- for the receiving antenna the standard uncertainty is 0,50 dB.

Test methods: Not applicable.

U_{j08} Mutual coupling: amplitude effect of the test antenna on the EUT

This uncertainty only contributes to test methods on free field test sites. It is the uncertainty that results from the interaction (impedance changes, etc.) between the EUT and the test antenna when placed close together.

How to evaluate for free field test sites

Verification: Not applicable.

Test methods: This is the uncertainty that results from the interaction (impedance changes, etc.) between the EUT and the test antenna when placed close together. The standard uncertainty should be taken from table D.4.

Table D.4: Uncertainty contribution: mutual coupling: amplitude effect of the test antenna on the EUT

Range length	Standard uncertainty of the contribution
$0,62\sqrt{((d_1+d_2)^3/\lambda)} \leq \text{range length} < 2(d_1+d_2)^2/\lambda$	0,50 dB
$\text{range length} \geq 2(d_1+d_2)^2/\lambda$	0,00 dB
NOTE: d_1 and d_2 are the maximum dimensions of the EUT and the test antenna.	

U_{j09} Mutual coupling: de-tuning effect of the test antenna on the EUT

This uncertainty only contributes to test methods on free field test sites that incorporate anechoic materials. It is the uncertainty of any de-tuning effect due to mutual coupling between the EUT and the test antenna.

How to evaluate for free field test sites

Verification: Not applicable.

Test methods: This value will be 0,00 Hz provided the spacing between the test antenna and EUT is greater than $(d_1+d_2)^2/4\lambda$. For lesser spacing, the value should be taken as 5 Hz standard uncertainty.

NOTE: d_1 and d_2 are the maximum dimensions of the EUT and the test antenna.

U_{j10} Mutual coupling: transmitting antenna to receiving antenna

This uncertainty only contributes to verification procedures on free field test sites. It is the uncertainty which results from the change in coupled signal level between the transmitting and receiving antenna when placed close together.

How to evaluate for free field test sites

Verification: For ANSI dipoles the value of this uncertainty is 0,00 dB since it is included, where significant, in the mutual coupling and mismatch loss correction factors. For non-ANSI dipoles the standard uncertainty can be taken from table D.5.

Table D.5: Uncertainty contribution: mutual coupling: transmitting antenna to receiving antenna

Frequency	Standard uncertainty of the contribution (3 m range)	Standard uncertainty of the contribution (10 m range)
$30 \text{ MHz} \leq \text{frequency} < 80 \text{ MHz}$	1,73 dB	0,60 dB
$80 \text{ MHz} \leq \text{frequency} < 180 \text{ MHz}$	0,6 dB	0,00 dB
$\text{frequency} \geq 180 \text{ MHz}$	0,00 dB	0,00 dB

Test methods: Not applicable.

U_{j11} Mutual coupling: substitution or measuring antenna to the test antenna

This uncertainty only contributes to test methods on free field test sites. It is the uncertainty which results from the change in coupled signal level between the substitution or measuring and test antenna when placed close together.

How to evaluate for free field test sites

Verification: Not applicable.

Test methods: For ANSI dipoles the value of this uncertainty is 0,00 dB since it is included, where significant, in the mutual coupling and mismatch loss correction factors. For non-ANSI dipoles the standard uncertainty can be taken from table D.6.

Table D.6: Uncertainty contribution: mutual coupling: substitution or measuring antenna to the test antenna

Frequency	Standard uncertainty of the contribution (3 m range)	Standard uncertainty of the contribution (10 m range)
30 MHz ≤ frequency < 80 MHz	1,73 dB	0,60 dB
80 MHz ≤ frequency < 180 MHz	0,6 dB	0,00 dB
frequency ≥ 180 MHz	0,00 dB	0,00 dB

 U_{j12} Mutual coupling: interpolation of mutual coupling and mismatch loss correction factors

This uncertainty contributes to test methods and verification procedures on free field test sites. It is the uncertainty that results from the interpolation between two values in the mutual coupling and mismatch loss correction factor table (given in the relevant test methods and verification procedures).

How to evaluate for free field test sites

Verification: The standard uncertainty can be obtained from table D.7.

Table D.7: Uncertainty contribution: mutual coupling: interpolation of mutual coupling and mismatch loss correction factors

Frequency (MHz)	Standard uncertainty of the contribution
for a spot frequency given in the table	0,00 dB
30 MHz ≤ frequency < 80 MHz	0,58 dB
80 MHz ≤ frequency < 180 MHz	0,17 dB
frequency ≥ 180 MHz	0,00 dB

Test methods: The standard uncertainty can be obtained from table D.7.

 U_{j13} Mutual coupling: EUT to its image in the ground plane

This uncertainty contributes to test methods on free field test sites that incorporate a ground plane. It is the uncertainty that results from the change in gain and/or sensitivity of an EUT when placed close to a ground plane.

How to evaluate for free field test sites

Verification: Not applicable.

Test methods: The standard uncertainty can be obtained from table D.8.

Table D.8: Uncertainty contribution: mutual coupling: EUT to its image in the ground plane

Spacing between the EUT and the ground plane	Standard uncertainty of the contribution
For a vertically polarized EUT	
spacing ≤ 1,25 l	0,15 dB
spacing > 1,25 l	0,06 dB
For a horizontally polarized EUT	
spacing < $l/2$	1,15 dB
$l/2$ ≤ spacing < $3l/2$	0,58 dB
$3l/2$ ≤ spacing < $3l$	0,29 dB
spacing ≥ $3l$	0,15 dB

U_{j14} Mutual coupling: substitution, measuring or test antenna to its image in the ground plane

This uncertainty only contributes to test methods on free field test sites that incorporate a ground plane. It is the uncertainty that results from the change in input impedance and/or gain of the substitution, measuring or test antenna when placed close to a ground plane.

How to evaluate for free field test sites

Verification: Not applicable.

Test methods: The standard uncertainty can be obtained from table D.9.

Table D.9: Uncertainty contribution: mutual coupling: substitution, measuring or test antenna to its image in the ground plane

Spacing between the antenna and the ground plane	Standard uncertainty of the contribution
For a vertically polarized antenna	
Spacing $\leq 1,25 l$	0,15 dB
Spacing $> 1,25 l$	0,06 dB
For a horizontally polarized antenna	
spacing $< l/2$	1,15 dB
$l/2 \leq$ spacing $< 3l/2$	0,58 dB
$3l/2 \leq$ spacing $< 3l$	0,29 dB
spacing $\geq 3l$	0,15 dB

U_{j15} Mutual coupling: transmitting or receiving antenna to its image in the ground plane

This uncertainty only contributes to verification procedures on free field test sites that incorporate a ground plane. It is the uncertainty that results from the change in gain of the transmitting or receiving antenna when placed close to a ground plane.

How to evaluate for free field test sites

Verification: For ANSI dipoles the value of this uncertainty is 0,00 dB as it is included, where significant, in the mutual coupling and mismatch loss correction factors. For other dipoles the value can be obtained from table D.10.

Table D.10: Uncertainty contribution: mutual coupling: transmitting or receiving antenna to its image in the ground plane

Spacing between the antenna and the ground plane	Standard uncertainty of the contribution
For a vertically polarized antenna	
spacing $\leq 1,25 l$	0,15 dB
spacing $> 1,25 l$	0,06 dB
For a horizontally polarized antenna	
spacing $< l/2$	1,15 dB
$l/2 \leq$ spacing $< 3l/2$	0,58 dB
$3l/2 \leq$ spacing $< 3l$	0,29 dB
spacing $\geq 3l$	0,15 dB

Test methods: Not applicable.

D.3 Range length

Background: The range length over which any radiated test is carried out should always be adequate to enable far field testing. It may also be specified in the relevant testing standard.

NOTE: Range length is defined as the horizontal distance between the phase centres of the EUT and the test antenna.

Over a reflective ground plane where a height scan is involved to peak the received signal the distance over which a measurement is performed is not always equal to the range length. Figure D.2 illustrates the difference between range length and measurement distance.

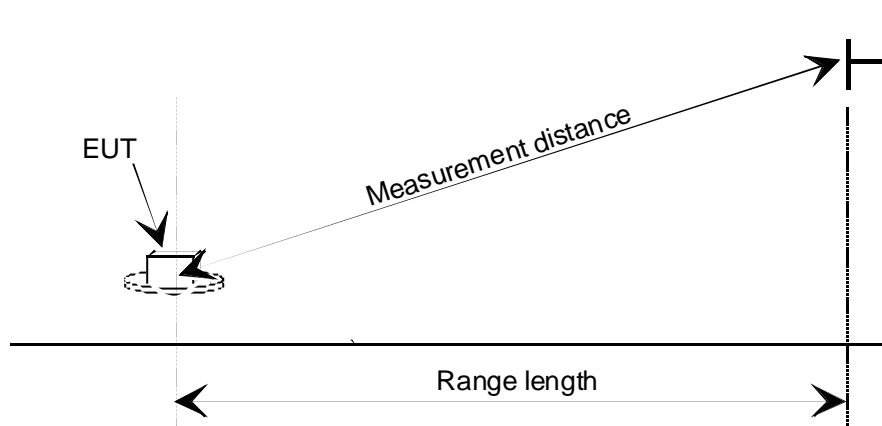

Figure D.2: Range length and measurement distance

It is important to distinguish clearly between these two terms.

U_{j16} Range length

This uncertainty contributes to test methods and verification procedures on free field test sites. It is the uncertainty associated with the curvature of the phase front resulting from inadequate range length between an EUT and antenna or, alternatively, between two antennas i.e. it should always be equal to or greater than $2(d_1+d_2)^2/l$.

NOTE: d_1 and d_2 are the maximum dimensions of the antennas.

How to evaluate for free field test sites

Verification: If ANSI dipoles are used the value is 0,00 dB, since it is included in the mutual coupling and mismatch loss correction factors, otherwise the value should be taken from table D.11.

Table D.11: Uncertainty contribution: range length (verification)

Range length (i.e. the horizontal distance between phase centres)	Standard uncertainty of the contribution
$(d_1+d_2)^2/4l \leq \text{range length} < (d_1+d_2)^2/2l$	1,26 dB
$(d_1+d_2)^2/2l \leq \text{range length} < (d_1+d_2)^2/l$	0,30 dB
$(d_1+d_2)^2/l \leq \text{range length} < 2(d_1+d_2)^2/l$	0,10 dB
$\text{range length} \geq 2(d_1+d_2)^2/l$	0,00 dB
NOTE: d_1 and d_2 are the maximum dimensions of the antennas.	

Test methods: For the EUT to test antenna stage the value should be taken from table D.12. For the substitution or measuring antenna to the test antenna stage: if ANSI dipoles are used the value is 0,00 dB, since it is included in the mutual coupling and mismatch loss correction factors, otherwise the value should be taken from table D.12.

Table D.12: uncertainty contribution: range length (test methods)

Range length (i.e. the horizontal distance between phase centres)	Standard uncertainty of the contribution
$(d_1+d_2)^2/4l \leq \text{range length} < (d_1+d_2)^2/2l$	1,26 dB
$(d_1+d_2)^2/2l \leq \text{range length} < (d_1+d_2)^2/l$	0,30 dB
$(d_1+d_2)^2/l \leq \text{range length} < 2(d_1+d_2)^2/l$	0,10 dB
$\text{range length} \geq 2(d_1+d_2)^2/l$	0,00 dB
NOTE: d_1 and d_2 are the maximum dimensions of the EUT and the test antenna used in one stage and are the maximum dimensions of the two antennas in the other stage.	

D.4 Corrections

Background: In radiated tests the height of the test antenna is optimized in each stage of the test, often the heights for the two stages are different. This leads to different measuring distances and elevation angles and corrections should be applied to take account of these effects.

U_{j17} Correction: off boresight angle in elevation plane

This uncertainty only contributes to test methods on free field test sites that incorporate a ground plane. Where the height of the antenna on the mast differs between the two stages of a particular measurement, two different elevation angles are subtended between the turntable and the test antenna. A correction factor should be applied to compensate. Its magnitude should be calculated using figure D.7 according to the guidance given in the test method. This uncertainty contribution is the estimate of the accuracy of the calculated correction factor and it only applies when the test antenna has a directional radiation pattern in the elevation plane see figure D.3.

NOTE: Figure D.7 applies to vertically polarized dipoles and bicones and to both polarizations of LPDAs. For horns, or any other type of antenna, figure D.7 is inappropriate and the test engineer should provide specific corrections.

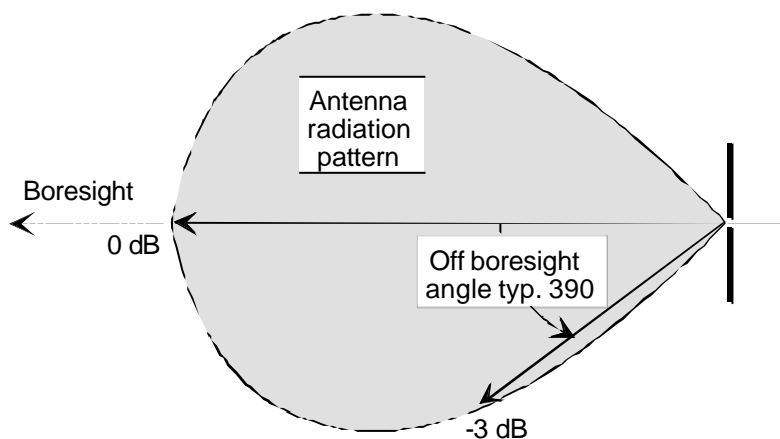

Figure D.3: Off boresight correction

How to evaluate for free field test sites

Verification: Not applicable.

Test methods:

For any antenna:

- Where the optimized height of the antenna on the mast is the same in the two stages of the test, this value is 0,00 dB.
- For vertically polarized dipoles and bicones where the optimized height of the antenna on the mast is different in the two stages of the test, the standard uncertainty of the value is 0,10 dB.
- For horizontally or vertically polarized LPDAs where the optimized height of the antenna on the mast is different in the two stages of the test, the standard uncertainty of the value is 0,50 dB.
- For any other antenna, **after application of a correction specific to that antenna**, where the optimized height of the antenna on the mast is different in the two stages of the test, the standard uncertainty of the value is 0,50 dB.

U_{j18} Correction: measurement distance

This uncertainty only contributes to test methods on free field test sites that incorporate a ground plane. Where the height of the antenna on the mast differs between the two stages of a particular measurement, two different path losses result from the different measurement distances involved. A correction factor should be applied to compensate. Its magnitude should be calculated according to the guidance given in the test method. This uncertainty contribution is the estimate of the accuracy of the calculated correction factor.

How to evaluate for free field test sites

Verification: Not applicable.

Test methods:

- Where the optimized height of the antenna on the mast is the same in the two stages of the test, this value is 0,00 dB.
- Where the optimized height of the antenna on the mast is different in the two stages of the test, the standard uncertainty of the value is 0,10 dB.

D.5 Radio frequency cables

Background: There are radiating mechanisms by which RF cables can introduce uncertainties into radiated measurements:

- leakage;
- acting as a parasitic element to an antenna;
- introducing common mode current.

Leakage allows electromagnetic coupling into the cables. Because the electromagnetic wave contains both electric and magnetic fields, mixed coupling occurs and the voltage induced is very dependant on the orientation, with respect to the cable, of the electric and magnetic fields. This coupling can have different effects depending on the length of the cable and where it is in the system. Cables are usually the longest part of the test equipment configuration and as such, leakage can make them act as efficient receiving or transmitting antennas that, as a result, will contribute significantly to the uncertainty of the measurement.

The parasitic effect of the cable can potentially be the most significant of the three effects and can cause major changes to the antenna's radiation pattern, gain and input impedance. The common mode current problem has similar effects on an antenna's performance.

Routing and loading the cables with ferrite beads as detailed in the test methods can largely eliminate all three effects. An RF cable for which no precautions have been taken to prevent these effects can, simply by being repositioned, cause different results to be obtained.

U_{j19} *Cable factor*

This uncertainty contributes to test methods and verification procedures. Cable factor is defined as the total effect of the RF cable's influence on the measuring system.

How to evaluate for free field test sites

Verification: In the direct attenuation stage of the procedure (a conducted measurement) all fields are enclosed and hence the contribution is assumed to be zero. However in the radiated attenuation stage, the standard uncertainty for each cable is 0,5 dB provided the precautions detailed in the procedure have been observed. If the precautions have not been observed the contributions have a standard uncertainty of 4,0 dB.

Test methods: The standard uncertainty for each cable is 0,5 dB provided the precautions detailed in the method have been observed. If the precautions have not been observed the contributions have a standard uncertainty of 4,0 dB.

Exceptionally, where a cable and antenna combination has not been repositioned between the two stages (as in the case of the test antenna in an Anechoic Chamber) and the precautions detailed in the procedure have been observed, the contribution is assumed to be 0,00 dB. If the combination has not been repositioned but the precautions have not been observed the contribution is 0,5 dB.

NOTE: Repositioning means any change in the positions of either the cable or the antenna in stage two of the measurement relative to stage one e.g. height optimization over a ground plane.

D.6 Phase centre positioning

Background: The phase centre of an EUT or antenna is the point from which the device is considered to radiate. If the device is rotated about this point the phase of the signal, as seen by a fixed antenna, does not change. It is therefore critical to (a) Identify the phase centre of an EUT or antenna and (b) to position it correctly on the test site.

U_{j20} *Position of the phase centre: within the EUT volume*

This uncertainty only contributes to test methods. It is the accuracy with which the phase centre is identified within the EUT.

How to evaluate for free field test sites

Verification: Not applicable.

Test methods: Only applicable in the stage in which the EUT is measured. If the precise phase centre is unknown, the uncertainty contribution should be calculated from:

$$\frac{\pm \text{the maximum dimension of the device}}{\text{twice the range length}} \times 100 \%$$

As the phase centre can be anywhere inside the EUT this uncertainty is assumed to be rectangularly distributed (see TR 102 273-1-1 [3], clause 5.1.2). The standard uncertainty can therefore be calculated and converted to the logarithmic form (see TR 102 273-1-2 [4], annex C).

U_{j21} *Positioning of the phase centre: within the EUT over the axis of rotation of the turntable*

This uncertainty only contributes to test methods. It is the accuracy with which the identified phase centre of the EUT is aligned with the axis of rotation of the turntable.

How to evaluate for free field test sites

Verification: Not applicable.

Test methods: Only applicable in the stage in which the EUT is measured. The maximum value should be calculated from:

$$\frac{\pm \text{the estimated offset from the axis of rotation}}{\text{range length}} \times 100\%$$

As this error source can be anywhere between these limits this uncertainty is assumed to be rectangularly distributed (see TR 102 273-1-1 [3], clause 5.1.2). The standard uncertainty can therefore be calculated and converted to the logarithmic form (see TR 102 273-1-2 [4], annex C).

 U_{j22} Position of the phase centre: measuring, substitution, receiving, transmitting or test antenna

This uncertainty contributes to test methods and verification procedures on free field test sites. It is the uncertainty with which the phase centre can be positioned.

How to evaluate for free field test sites

Verification:

For the transmitting antenna the maximum value should be calculated from:

$$\frac{\pm \text{the estimated offset from the axis of rotation}}{\text{range length}} \times 100\%$$

For the receiving antenna in an Anechoic Chamber the maximum value should be calculated from:

$$\frac{\pm \text{the uncertainty with which the range length can be set}}{\text{range length}} \times 100\%$$

For the receiving antenna over a ground plane the maximum value should be calculated from:

$$\frac{\pm \text{the maximum estimated deflection from vertical of the top of the mast}}{\text{range length}} \times 100\%$$

As this error source can be anywhere between these limits this uncertainty is assumed to be rectangularly distributed (see TR 102 273-1-1 [3], clause 5.1.2). The standard uncertainty can therefore be calculated and converted to the logarithmic form (see TR 102 273-1-2 [4], annex C).

Test methods:

For the measuring and substitution antennas the maximum value should be calculated from:

$$\frac{\pm \text{the estimated offset from the axis of rotation}}{\text{range length}} \times 100\%$$

For the test antenna in an Anechoic Chamber the maximum value should be calculated from:

$$\frac{\pm \text{the uncertainty with which the range length can be set}}{\text{range length}} \times 100\%$$

For the test antenna over a ground plane the maximum value should be calculated from:

$$\frac{\pm \text{the maximum estimated deflection from vertical of the top of the mast}}{\text{range length}} \times 100\%$$

As this error source can be anywhere between these limits this uncertainty is assumed to be rectangularly distributed (see TR 102 273-1-1 [3], clause 5.1.2). The standard uncertainty can therefore be calculated and converted to the logarithmic form (see TR 102 273-1-2 [4], annex C).

U_{j23} *Position of the phase centre: LPDA*

This uncertainty contributes to test methods and verification procedures on free field test sites. It is the uncertainty associated with the changing position of the phase centre with frequency of the LPDA.

How to evaluate for free field test sites

Verification: The maximum value should be calculated from:

$$\frac{\pm \text{the maximum dimension of the device}}{\text{twice the range length}} \times 100 \%$$

As this error source can be anywhere between these limits this uncertainty is assumed to be rectangularly distributed (see TR 102 273-1-1 [3], clause 5.1.2). The standard uncertainty can therefore be calculated and converted to the logarithmic form (see TR 102 273-1-2 [4], annex C).

Test methods: For the test antenna the contribution is 0,00 dB. For the substitution or measuring LPDA the maximum value should be calculated from:

$$\frac{\pm \text{the length of the LPDA}}{\text{twice the range length}} \times 100 \%$$

As this error source can be anywhere between these limits this uncertainty is assumed to be rectangularly distributed (see TR 102 273-1-1 [3], clause 5.1.2). The standard uncertainty can therefore be calculated and converted to the logarithmic form (see TR 102 273-1-2 [4], annex C).

D.7 Not used

D.8 Ambient signals

Background: Ambient signals are localized sources of radiated transmissions that can introduce uncertainty into the results of a test made on an Open Area Test Site and in unshielded Anechoic Chambers.

 U_{j34} *Ambient effect*

This uncertainty contributes to test methods and verification procedures on free field test sites. It is the uncertainty caused by local ambient signals raising the noise floor of the receiver at the frequency of test.

How to evaluate for free field test sites

Verification: The values of the standard uncertainties should be taken from table D.15.

Table D.15: Uncertainty contribution: ambient effect

Receiving device noise floor (with signal generator OFF) is within:	Standard uncertainty of the contribution
3 dB of measurement	1,57 dB
3 dB to 6 dB of measurement	0,80 dB
6 dB to 10 dB of measurement	0,30 dB
10 dB to 20 dB of measurement	0,10 dB
20 dB or more of the measurement	0,00 dB

Test methods: The values of the standard uncertainties should be taken from table D.15.

D.9 Mismatch

Background: When two or more items of RF test equipment are connected together a degree of mismatch occurs. Associated with this mismatch there is an uncertainty component as the precise interactions are unknown. Mismatch uncertainties are calculated in the present document using S -parameters and full details of the method are given in TR 102 273-1-2 [4], annex D. For our purposes the measurement set-up consists of components connected in series, i.e. cables, attenuators, antennas, etc. and for each individual component in this chain, the attenuation and VSWRs needs to be known or assumed. The exact values of the VSWRs (which in RF circuits are complex values) are usually unknown at the precise frequency of test although worst case values over an extended frequency band will be known. It is these worst case values that should be used in the calculations. This approach will generally cause the calculated mismatch uncertainties to be worse than they actually are.

U_{j35} Mismatch: direct attenuation measurement

This uncertainty only contributes to verification procedures. It results from the interaction of the VSWRs of the components in the direct attenuation measurement. The direct attenuation measurement refers to the arrangement in which the signal generator is directly connected to the receiving device (via cables, attenuators and an adapter) to obtain a reference signal level (see figure D.4). Due to load variations (antennas replacing the adapter in the second stage of the procedure) contributions are not identical in the two stages of the verification procedure.

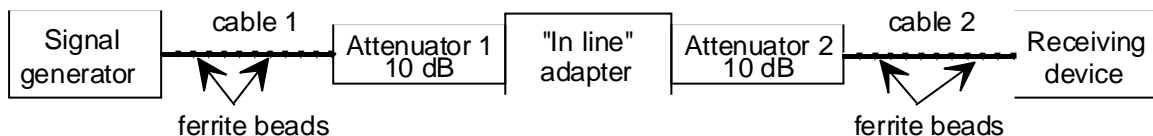

Figure D.4: Equipment set-up for the direct attenuation measurement

How to evaluate for free field test sites

Verification: The magnitude of the uncertainty contribution due to the mismatch in the direct attenuation measurement, is calculated from the approach described in TR 102 273-1-2 [4], annex D.

Test methods: Not applicable

U_{j36} Mismatch: transmitting part

This uncertainty contributes to test methods and verification procedures. The transmitting part refers to the signal generator, cable, attenuator and antenna set-up shown in figure D.5. This equipment configuration is used for:

- the transmitting part of a free field test site verification procedure;
- the transmitting part of the substitution measurement in a transmitter test method;
- the transmitting part when generating a field in a receiver test method.

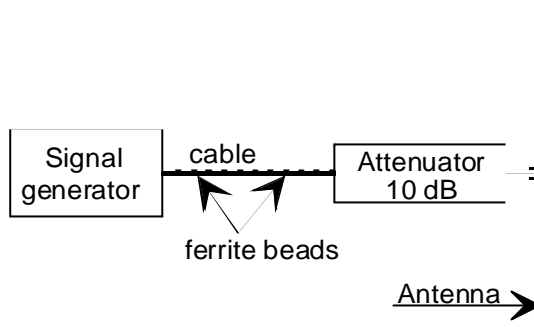

Figure D.5: Equipment set-up for the transmitting part

How to evaluate for free field test sites

Verification: The uncertainty contribution due to the mismatch in the transmitting part is calculated from the approach described in TR 102 273-1-2 [4], annex D.

Test methods: As for the verification.

U_{j37} Mismatch: receiving part

This uncertainty contributes to test methods and verification procedures. The receiving part refers to the antenna, attenuator, cable and receiving device set-up shown in figure D.6. This equipment configuration is used for:

- the receiving part of a free field test site verification procedure;
- the receiving part of the substitution measurement in a transmitter test method;
- the receiving part when measuring the field in a receiver test method.

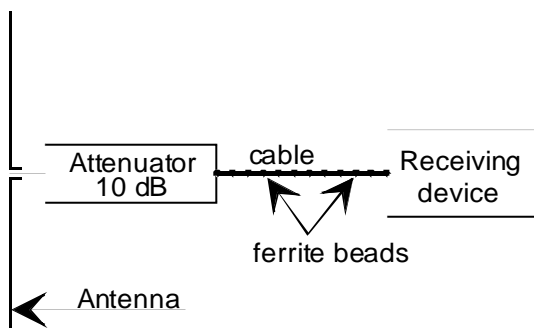

Figure D.6: Equipment set-up for the receiving part

How to evaluate for free field test sites

Verification: The uncertainty contribution due to the mismatch in the receiving part is calculated from the approach described in TR 102 273-1-2 [4], annex D.

Test methods: As for the verification.

D.10 Signal generator

Background: The signal generator is used as the transmitting source. There are two signal generator characteristics that contribute to the expanded uncertainty of a measurement: absolute level and level stability.

U_{j38} *Signal generator: absolute output level*

This uncertainty only contributes to test methods. It concerns the accuracy with which an absolute signal generator level can be set.

How to evaluate for free field test sites

Verification: The standard uncertainty is 0,00 dB.

Test methods: The uncertainty contribution should be taken from the manufacturer's data sheet and converted into standard uncertainty if necessary.

U_{j39} *Signal generator: output level stability*

This uncertainty contributes to test methods and verification procedures. It concerns the stability of the output level. In any test in which the contribution of the absolute level uncertainty of the signal generator contributes to the combined standard uncertainty of the test i.e. it does not cancel due to the methodology, the contribution from the output level stability is considered to have been included in the signal generator absolute output level, u_{j38} . Conversely, for any level in which the absolute level uncertainty of the signal generator does not contribute to the combined standard uncertainty, the output level stability of the signal generator should be included. The standard uncertainty of the contribution due to the signal generator output level stability is designated throughout all parts of the present document as u_{j39} . Its value can be derived from manufacturer's data sheet.

How to evaluate for free field test sites

Verification: The uncertainty contribution should be taken from the manufacturer's data sheet and converted into standard uncertainty if necessary.

Test methods: The standard uncertainty of the contribution due to the signal generator output level stability is taken as 0,00 dB as it is covered by the absolute level uncertainty.

D.11 Insertion losses

Test equipment components such as attenuators, cables, adapters, etc. have insertion losses at a given frequency that act as systematic offsets. Knowing the value of the insertion losses allows the results to be corrected by the offsets. However, there are uncertainties associated with these insertion losses that are equivalent to the uncertainty of the loss measurements.

U_{j40} *insertion loss: attenuator*

This uncertainty only contributes to test methods.

How to evaluate for free field test sites

Verification: This value is 0,00 dB.

Test methods:

- for the attenuator associated with the test antenna this uncertainty contribution is common to both stage one and stage two of the measurement. Consequently, this uncertainty contribution is assumed to be 0,00 dB due to the methodology;
- for the attenuator associated with the substitution or measuring antenna this uncertainty contribution is taken either from the manufacturer's data sheet or from the combined standard uncertainty figure of its measurement.

 U_{j41} Insertion loss: cable

This uncertainty only contributes to the test methods.

How to evaluate for free field test sites

Verification: This value is 0,00 dB.

Test methods:

- for the cable associated with the test antenna, this uncertainty contribution is common to both stage one and stage two of the measurement. Consequently, it is assumed to be 0,00 dB due to the methodology.
- for the cable associated with the substitution or measuring antenna, this uncertainty contribution is taken either from the manufacturer's data sheet or from the combined standard uncertainty figure of its measurement.

 U_{j42} Insertion loss: adapter

This uncertainty only contributes to the verification procedures.

How to evaluate for free field test sites

Verification: This uncertainty contribution is taken either from the manufacturer's data sheet or from the combined standard uncertainty figure of the loss measurement.

Test methods: Not applicable.

 U_{j43} Insertion loss: antenna balun

This uncertainty contributes to test methods and verification procedures on free field test sites.

How to evaluate for free field test sites

Verification: The standard uncertainty of the contribution is 0,17 dB.

Test methods: The standard uncertainty of the contribution is 0,17 dB.

D.12 Antennas

Background: Antennas are used to launch or receive radiated fields on free field test sites. They can contribute to measurement uncertainty in several ways. For example, the uncertainty of the gain and/or antenna factor, the tuning, etc.

U_{j44} *Antenna: antenna factor of the transmitting, receiving or measuring antenna*

This uncertainty contributes to test methods and verification procedures on free field test sites. It is the uncertainty with which the antenna factor is known at the frequency of test.

How to evaluate for free field test sites

Verification: The antenna factor contributes only to the radiated part of this procedure. For ANSI dipoles the value should be obtained from table D.16. For other antenna types the figures should be taken from manufacturer's data sheets. If a figure is not given the standard uncertainty is 1,0 dB.

Table D.16: Uncertainty contribution: antenna: antenna factor of the transmitting, receiving or measuring antenna

Frequency	Standard uncertainty of the contribution
30 MHz ≤ frequency < 80 MHz	1,73 dB
80 MHz ≤ frequency < 180 MHz	0,60 dB
frequency ≥ 180 MHz	0,30 dB

Test methods: The uncertainty contribution should be taken from the manufacturer's data sheet and converted into standard uncertainty if necessary. If no value is given the standard uncertainty is assumed to be 1,0 dB.

U_{j45} *Antenna: gain of the test or substitution antenna*

This uncertainty only contributes to test methods on free field test sites. It is the uncertainty with which the gain of the antenna is known at the frequency of test.

How to evaluate for free field test sites

Verification: Not applicable.

Test methods: For ANSI dipoles the value should be obtained from table D.17. For other antenna types the figures should be taken from manufacturer's data sheets. If a figure is not given the standard uncertainty is 1,0 dB.

Table D.17: Uncertainty contribution: antenna: gain of the test or substitution antenna

Frequency	Standard uncertainty of the contribution
30 MHz ≤ frequency < 80 MHz	1,73 dB
80 MHz ≤ frequency < 180 MHz	0,60 dB
frequency ≥ 180 MHz	0,30 dB

U_{j46} *Antenna: tuning*

This uncertainty contributes to test methods and verification procedures on free field test sites. It is the uncertainty with which the lengths of the dipoles arms can be set for any test frequency.

How to evaluate for free field test sites

Verification: The standard uncertainty is 0,06 dB.

Test methods:

- In the test antenna case the uncertainty is equal in both stages of the test method so its contribution to the uncertainty is assumed to be 0,00 dB.
- In the substitution/measuring antenna case, the standard uncertainty is 0,06 dB.

D.13 Receiving device

Background: The receiving device (a measuring receiver or spectrum analyser) is used to measure the received signal level either as an absolute level or as a reference level. It can contribute uncertainty components in two ways: absolute level accuracy and non-linearity. An alternative receiving device (a power measuring receiver) is used for the adjacent channel power test method.

U_{j47} *Receiving device: absolute level*

This uncertainty contributes to test methods where the measurement of field strength is involved and the verification procedures where a range change to the receiving device's input attenuator occurs between the two stages of the procedure.

How to evaluate for free field test sites

Verification: The absolute level uncertainty is not applicable in stage one but should be included in stage two if the receiving device's input attenuator has been changed. This uncertainty contribution should be taken from the manufacturer's data sheet and converted if necessary.

Test methods: Only applicable in the electric field strength measurement stage for a receiving equipment. This uncertainty contribution should be taken from the manufacturer's data sheet and converted if necessary.

U_{j48} *Receiving device: linearity*

This uncertainty only contributes to the verification procedures.

How to evaluate for free field test sites

Verification: If the receiving devices input attenuator has been changed the value is 0,00 dB. If not, the value should be calculated from the manufacturer's data sheet e.g.: a level variation of 62 dB gives an uncertainty of 0,62 dB at a linearity of 0,1 dB/10 dB. The uncertainty should be converted into standard uncertainty, assuming a rectangular distribution in logs.

Test methods: Not applicable.

U_{j49} *Receiving device: power measuring receiver*

This uncertainty only contributes to the transmitter adjacent channel power test method. There are three types of power measuring receiver, they are:

- an adjacent channel power meter;
- a spectrum analyser;
- a measuring receiver with digital filters.

How to evaluate for free field test sites

Verification: Not applicable.

Test methods: Contributions are the same as for the conducted case, see TR 100 028 [1 and 2].

D.14 Equipment under test

Background: There are uncertainties associated with the EUT due to the following reasons:

- temperature effects: this is the uncertainty caused by the uncertainty in the ambient temperature;
- degradation measurement: this contribution is a RF level uncertainty associated with the uncertainty of measuring, 20 dB SINAD, 10^{-2} bit stream or 80 % message acceptance ratio;
- power supply effects. this is the uncertainty caused by the uncertainty in the power supply voltage;
- mutual coupling to its power leads.

U_{j50} EUT: influence of the ambient temperature on the ERP of the carrier

This uncertainty only contributes to the ERP test method. It is the uncertainty in the carrier power level caused by the uncertainty in knowing the ambient temperature.

How to evaluate for free field test sites

Verification: Not applicable.

Test methods: Only applicable in stage one where the measurement is made on the EUT. The uncertainty caused is calculated using the dependency function (TR 100 028 [1 and 2]) whose mean value is 4 %/°C and whose standard deviation is 1,2 %/°C. The standard uncertainty of the ERP of the carrier caused by this ambient temperature uncertainty should be calculated using the appropriate formula of TR 100 028 [1 and 2] and then converted to dB.

For example, an ambient temperature uncertainty of ± 1 °C, results in the standard uncertainty of the ERP of the carrier of:

$$\sqrt{\left(\frac{1^\circ\text{C}}{3}\right)^2 \times ((4,0\%/^\circ\text{C})^2 + (1,2\%/^\circ\text{C})^2)} = 2,41 \%, \text{ transformed to dB: } 2,41/23,0 = 0,1 \text{ dB}$$

U_{j51} EUT: influence of the ambient temperature on the spurious emission level

This uncertainty contribution only applies to the test methods on free field test sites. It is the uncertainty in the power level of the spurious emission caused by the uncertainty in knowing the ambient temperature.

How to evaluate for free field test sites

Verification: Not applicable.

Test methods: Only applicable in stage one where the measurement is made on the EUT. The uncertainty caused is calculated using the dependency function (TR 100 028 [1 and 2]) whose mean value is 4 %/°C and whose standard deviation is 1,2 %/°C. The standard uncertainty of the spurious emission level caused by this ambient temperature uncertainty should be calculated using the appropriate formula of TR 100 028 [1 and 2] and then converted to dB.

For example, an ambient temperature uncertainty of ± 1 °C, results in the standard uncertainty of the spurious emission level of:

$$\sqrt{\left(\frac{1^\circ\text{C}}{3}\right)^2 \times ((4,0\%/^\circ\text{C})^2 + (1,2\%/^\circ\text{C})^2)} = 2,41 \%, \text{ transformed to dB: } 2,41/23,0 = 0,1 \text{ dB.}$$

U_{j52} EUT: degradation measurement

This uncertainty only contributes to receiver test methods and is the resulting RF level uncertainty associated with the uncertainty of measuring 20 dB SINAD, 10⁻² bit stream or 80 % message acceptance ratio.

How to evaluate for free field test sites

Verification: Not applicable.

Test methods: The magnitude can be obtained from TR 100 028 [1 and 2].

U_{j53} EUT: influence of setting the power supply on the ERP of the carrier

This uncertainty only applies to the effective radiated power test method and is caused by the uncertainty in setting the power supply level.

How to evaluate for free field test sites

Verification: Not applicable.

Test methods: Only applicable in stage one where the measurement is made on the EUT. The uncertainty caused is calculated using the dependency function (TR 100 028 [1 and 2]) whose mean value is 10 %/V and whose standard deviation is 3 %/V. The standard uncertainty of the ERP of the carrier caused by power supply voltage uncertainty should be calculated using the appropriate formula of TR 100 028 [1 and 2] and then converted to dB.

For example, a supply voltage uncertainty of ±100 mV results in the standard uncertainty of the ERP of the carrier of:

$$\sqrt{\frac{(0,1V)^2}{3} \times ((10\%/V)^2 + (3\%/V)^2)} = 0,60 \%, \text{ transformed to dB: } 0,60/23,0 = 0,03 \text{ dB.}$$

U_{j54} EUT: influence of setting the power supply on the spurious emission level

This uncertainty only applies to the spurious emissions test method and is caused by the uncertainty in setting the power supply level.

How to evaluate for free field test sites

Verification: Not applicable.

Test methods: Only applicable in stage one where the measurement is made on the EUT. The uncertainty caused is calculated using the dependency function (TR 100 028 [1 and 2]) whose mean value is 10 %/V and whose standard deviation is 3 %/V. The standard uncertainty of the spurious emission level caused by power supply voltage uncertainty should be calculated using formula (2) of TR 100 028 [1 and 2] and then converted to dB.

For example, a supply voltage uncertainty of ±100 mV results in the standard uncertainty of the spurious emission level of:

$$\sqrt{\frac{(0,1V)^2}{3} \times ((10\%/V)^2 + (3\%/V)^2)} = 0,06 \%, \text{ transformed to dB: } 0,60/23,0 = 0,03 \text{ dB.}$$

U_{j55} *EUT: mutual coupling to the power leads*

This uncertainty only contributes to test methods. It is the uncertainty that results from interaction (reflections, parasitic effects, etc.) between the EUT and the power leads.

How to evaluate for free field test sites

Verification: Not applicable.

Test methods: The standard uncertainty is 0,5 dB provided that the precautions detailed in the methods have been observed, i.e. routing and dressing of cables with ferrites. If the precautions have not been observed the standard uncertainty is 2,0 dB.

D.15 Not used

D.16 Not used

D.17 Not used

D.18 Random uncertainty **U_{i01}** *Random uncertainty*

This uncertainty contributes to all radiated tests. It is the estimated effect that randomness has on the measurement.

NOTE: It is important to identify whether this value (the random uncertainty) corresponds to the effect of other uncertainties already taken into account in the calculations (e.g. uncertainties due to the instrumentation) or whether this is a genuine contribution of randomness. Obviously there are uncertainties in all measurements, so it has to be expected that performing the same measurement a number of times may provide a set of different results. When a contribution due to randomness has to be taken into account, care should be taken to ensure the measurement conditions are kept constant, as far as possible, throughout the repetition of the measurements.

How to evaluate for free field test sites

Verification: Random uncertainty should be assessed by multiple measurements of the same measurand and treating the results statistically to derive the standard uncertainty of its contribution.

Test methods: Random uncertainty should be assessed by multiple measurements of the same measurand and treating the results statistically to derive the standard uncertainty of its contribution.

D.19 Summary, tables and figures

Table D.19: Mutual coupling and mismatch loss correction factors (Anechoic Chamber)

Frequency (MHz)	Range length 3 m		Frequency (MHz)	Range length 10 m
30	27,1		30	25,8
35	24,3		35	23,3
40	21,7		40	20,8
45	19,0		45	18,2
50	16,1		50	15,4
60	9,7		60	9,1
70	2,2		70	1,7
80	0,7		80	0,2
90	0,6		90	0,1
100	0,6		100	0,1
120	0,3		120	0,1
140	0,4		140	0,1
160	0,3		160	0,2
180	0,2		180	0,1

Table D.20: Mutual coupling and mismatch loss correction factors (over a ground plane)

Freq. (MHz)	Horizontal polarization		Freq. (MHz)	Vertical polarization	
	3 m	10 m		3 m	10 m
30	27,6	26,0	30	25,2	25,4
35	24,6	23,3	35	22,4	22,9
40	21,8	20,7	40	19,8	20,4
45	19,0	18,1	45	17,2	17,9
50	16,0	15,1	50	14,4	15,1
60	9,5	8,9	60	8,5	9,2
70	2,4	2,8	70	1,6	2,5
80	0,6	0,8	80	0,0	0,4
90	0,2	0,4	90	-0,2	0,1
100	-0,3	0,0	100	-0,6	0,0
120	-2,3	-1,2	120	-0,6	0,0
140	-1,0	-0,7	140	1,1	-0,1
160	-0,3	0,3	160	0,7	0,0
180	-0,3	0,3	180	0,3	0,0

Table D.21: Summary table of all contributions (numerical sort)

	Description
u_{j01}	reflectivity of absorbing material: EUT to the test antenna
u_{j02}	reflectivity of absorbing material: substitution or measuring antenna to the test antenna
u_{j03}	reflectivity of absorbing material: transmitting antenna to the receiving antenna
u_{j04}	mutual coupling: EUT to its images in the absorbing material
u_{j05}	mutual coupling: de-tuning effect of the absorbing material on the EUT
u_{j06}	mutual coupling: substitution, measuring or test antenna to its image in the absorbing material
u_{j07}	mutual coupling: transmitting or receiving antenna to its image in the absorbing material
u_{j08}	mutual coupling: amplitude effect of the test antenna on the EUT
u_{j09}	mutual coupling: de-tuning effect of the test antenna on the EUT
u_{j10}	mutual coupling: transmitting antenna to the receiving antenna
u_{j11}	mutual coupling: substitution or measuring antenna to the test antenna
u_{j12}	mutual coupling: interpolation of mutual coupling and mismatch loss correction factors
u_{j13}	mutual coupling: EUT to its image in the ground plane
u_{j14}	mutual coupling: substitution, measuring or test antenna to its image in the ground plane
u_{j15}	mutual coupling: transmitting or receiving antenna to its image in the ground plane
u_{j16}	range length
u_{j17}	correction: off boresight angle in the elevation plane
u_{j18}	correction: measurement distance
u_{j19}	cable factor
u_{j20}	position of the phase centre: within the EUT volume
u_{j21}	positioning of the phase centre: within the EUT over the axis of rotation of the turntable
u_{j22}	position of the phase centre: measuring, substitution, receiving, transmitting or test antenna
u_{j23}	position of the phase centre: LPDA
u_{j34}	ambient effect
u_{j35}	mismatch: direct attenuation measurement
u_{j36}	mismatch: transmitting part
u_{j37}	mismatch: receiving part
u_{j38}	signal generator: absolute output level
u_{j39}	signal generator: output level stability
u_{j40}	insertion loss: attenuator
u_{j41}	insertion loss: cable
u_{j42}	insertion loss: adapter
u_{j43}	insertion loss: antenna balun
u_{j44}	antenna: antenna factor of the transmitting, receiving or measuring antenna
u_{j45}	antenna: gain of the test or substitution antenna
u_{j46}	antenna: tuning
u_{j47}	receiving device: absolute level
u_{j48}	receiving device: linearity
u_{j49}	receiving device: power measuring receiver
u_{j50}	EUT: influence of the ambient temperature on the ERP of the carrier
u_{j51}	EUT: influence of the ambient temperature on the spurious emission level
u_{j52}	EUT: degradation measurement
u_{j53}	EUT: influence of setting the power supply on the ERP of the carrier
u_{j54}	EUT: influence of setting the power supply on the spurious emission level
u_{j55}	EUT: mutual coupling to the power leads
u_{j01}	Random (see note in clause D.18 of the present document and note in clause 6.4.7 of TR 102 273-1-1)

Table D.22: Summary table of all contributions (alphabetical sort)

	Description
<i>u_{j34}</i>	<i>ambient effect</i>
<i>u_{j44}</i>	<i>antenna: antenna factor of the transmitting, receiving or measuring antenna</i>
<i>u_{j45}</i>	<i>antenna: gain of the test or substitution antenna</i>
<i>u_{j46}</i>	<i>antenna: tuning</i>
<i>u_{j19}</i>	<i>cable factor</i>
<i>u_{j18}</i>	<i>correction: measurement distance</i>
<i>u_{j17}</i>	<i>correction: off boresight angle in the elevation plane</i>
<i>u_{j53}</i>	<i>EUT: influence of setting the power supply on the ERP of the carrier</i>
<i>u_{j54}</i>	<i>EUT: influence of setting the power supply on the spurious emission level</i>
<i>u_{j50}</i>	<i>EUT: influence of the ambient temperature on the ERP of the carrier</i>
<i>u_{j51}</i>	<i>EUT: influence of the ambient temperature on the spurious emission level</i>
<i>u_{j52}</i>	<i>EUT: degradation measurement</i>
<i>u_{j55}</i>	<i>EUT: mutual coupling to the power leads</i>
<i>u_{j42}</i>	<i>insertion loss: adapter</i>
<i>u_{j43}</i>	<i>insertion loss: antenna balun</i>
<i>u_{j40}</i>	<i>insertion loss: attenuator</i>
<i>u_{j41}</i>	<i>insertion loss: cable</i>
<i>u_{j35}</i>	<i>mismatch: direct attenuation measurement</i>
<i>u_{j37}</i>	<i>mismatch: receiving part</i>
<i>u_{j36}</i>	<i>mismatch: transmitting part</i>
<i>u_{j04}</i>	<i>mutual coupling: EUT to its images in the absorbing material</i>
<i>u_{j08}</i>	<i>mutual coupling: amplitude effect of the test antenna on the EUT</i>
<i>u_{j05}</i>	<i>mutual coupling: de-tuning effect of the absorbing material on the EUT</i>
<i>u_{j09}</i>	<i>mutual coupling: de-tuning effect of the test antenna on the EUT</i>
<i>u_{j13}</i>	<i>mutual coupling: EUT to its image in the ground plane</i>
<i>u_{j12}</i>	<i>mutual coupling: interpolation of mutual coupling and mismatch loss correction factors</i>
<i>u_{j11}</i>	<i>mutual coupling: substitution or measuring antenna to the test antenna</i>
<i>u_{j06}</i>	<i>mutual coupling: substitution, measuring or test antenna to its image in the absorbing material</i>
<i>u_{j14}</i>	<i>mutual coupling: substitution, measuring or test antenna to its image in the ground plane</i>
<i>u_{j10}</i>	<i>mutual coupling: transmitting antenna to the receiving antenna</i>
<i>u_{j07}</i>	<i>mutual coupling: transmitting or receiving antenna to its image in the absorbing material</i>
<i>u_{j15}</i>	<i>mutual coupling: transmitting or receiving antenna to its image in the ground plane</i>
<i>u_{j23}</i>	<i>position of the phase centre: LPDA</i>
<i>u_{j22}</i>	<i>position of the phase centre: measuring, substitution, receiving, transmitting or test antenna</i>
<i>u_{j20}</i>	<i>position of the phase centre: within the EUT volume</i>
<i>u_{j21}</i>	<i>positioning of the phase centre: within the EUT over the axis of rotation of the turntable</i>
<i>u_{i01}</i>	<i>Random (see note in clause A.18 of the present document and note in clause 6.4.7 of TR 102 273-1-1)</i>
<i>u_{j16}</i>	<i>range length</i>
<i>u_{j47}</i>	<i>receiving device: absolute level</i>
<i>u_{j48}</i>	<i>receiving device: linearity</i>
<i>u_{j49}</i>	<i>receiving device: power measuring receiver</i>
<i>u_{j01}</i>	<i>reflectivity of absorbing material: EUT to the test antenna</i>
<i>u_{j02}</i>	<i>reflectivity of absorbing material: substitution or measuring antenna to the test antenna</i>
<i>u_{j03}</i>	<i>reflectivity of absorbing material: transmitting antenna to the receiving antenna</i>
<i>u_{j38}</i>	<i>signal generator: absolute output level</i>
<i>u_{j39}</i>	<i>signal generator: output level stability</i>

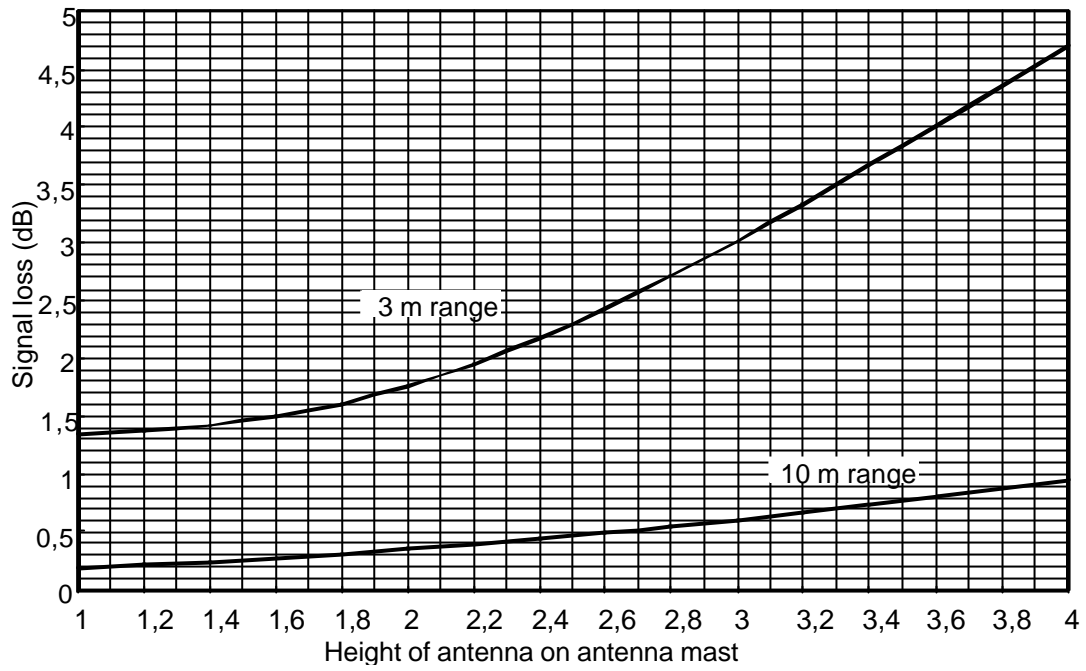

Figure D.7: Signal attenuation with increasing elevation offset angle

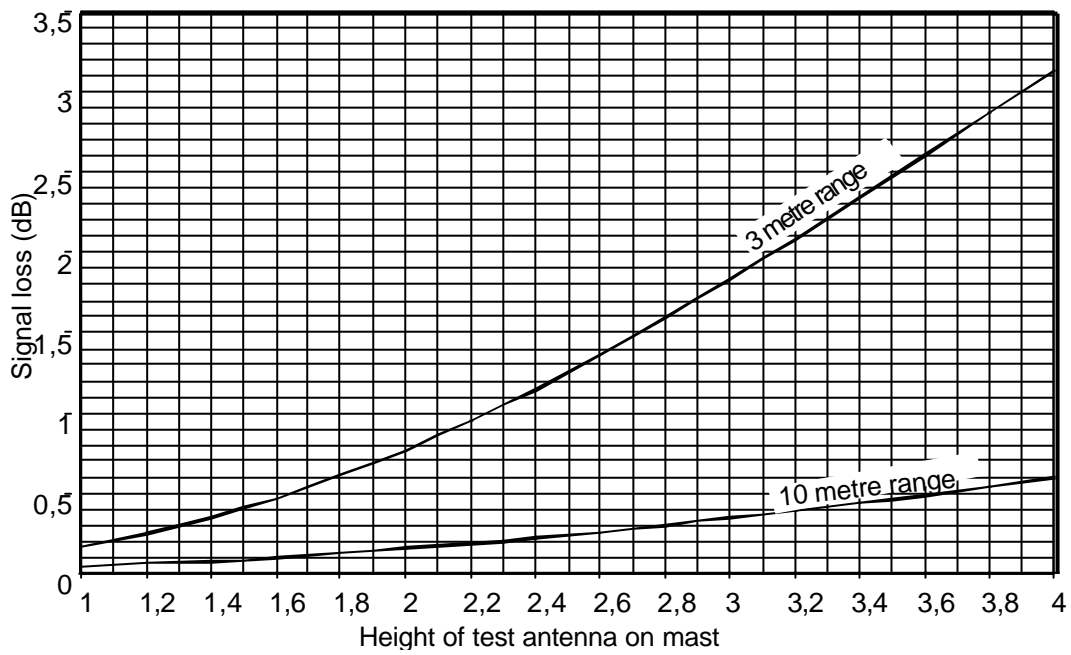

Figure D.8: Signal attenuation for antenna height on mast

History

Document history		
V1.1.1	August 2003	Publication
V1.1.2	September 2003	Publication
Draft V1.2.1	January 2004	Draft updated as consequence of phase 2 of STF 241 work and submitted for approval to TC ERM
Draft v1.2.1	March 2004	Draft updated from comments received for submission to TC-ERM#22 for approval
Draft v1.2.1	March 2004	Draft approved for publication at TC-ERM#22